



16



18



24

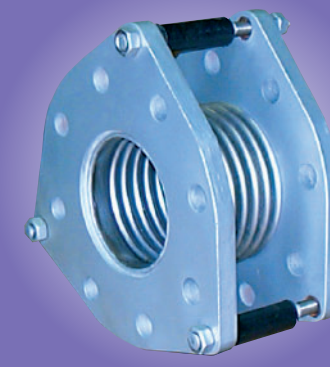

26

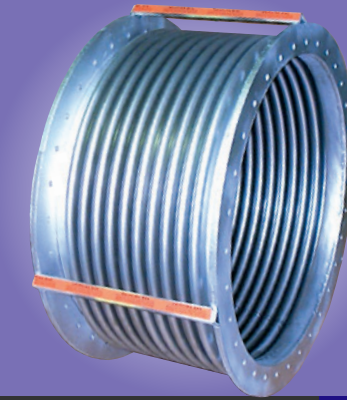

28

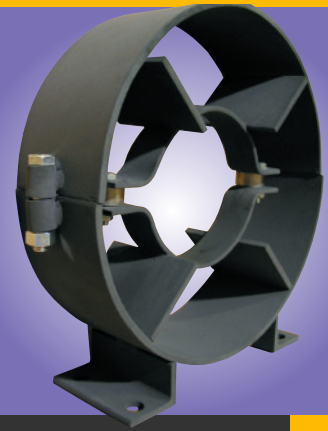

30

## Traditions Will Never Mean Limits.

We understand that no customer's requirements are exactly the same. That our audience is targeted to engineers/designers and construction contractors whose responsibilities are to oversee costs and quality in the physical realm of installation of piping systems to existing and newly constructed buildings.

That's why Flex-Hose Co. pays so much attention to the details of your experience. Our employees will greet you in such a way that says we truly care and appreciate the opportunity to meet your performance expectation. Flex-Hose Co. personnel have the technical training and ability to provide solutions to the most demanding application. Our support also extends through specific job analysis services which recommends placement of product location in a piping system, perfectly integrating them into the overall theme of your project, saving you both time and money. This is the result of staying true to what is essentially right.

## Anything Worth Doing is Worth Doing Right.

It's not very hard to understand that people are influenced by innovation, long-term reliability, ease of installation, and extreme cost savings. It's a no-brainer. This essence is built into the very fabric of our business and products since 1968.

Flex-Hose Co. expansion joints are engineered and manufactured for a broad range of requirements. They have been used in some of the most demanding applications worldwide. They are capable of isolating critical mechanical equipment from a piping or duct work system, thermal growth, dampen vibration, and reduce noise. Our renowned products are backed by the best warranties in the business that other manufacturers find easier to talk about than to duplicate.

Our expansion joint products have also been inspected and tested by the Technical Standards & Safety Authority of Canada, and hold a CSA Standard B51 Certificate to meet the high quality standards of the Canadian market.



So enjoy years of service with our flexible piping connections. Flex-Hose Co. products give you that choice. Don't compromise.

Phil Argersinger, President/Owner

# expansion joints

## metal bellows

### Form and Function.

To put both form and function together requires more than just providing quality products. Expansion joint's reliability depend on correct sizing, guiding and proper installation.

That's why we just don't provide expansion joints! It's perfect for those who wish to aim low and provide just product. But at Flex-Hose Co. we understand the criticalness of doing it right the first time. We look at your piping expansion system with the basic needs of handling thermal growth with reliability and emphasis on a no nonsense approach.

That is why thermal pipe expansion is in our blood. We provide more than simply the product. We will assist you in calculating thermal pipe growth, anchor location, product selection, and placement recommendation in your piping system.

So whether your application requires custom or standard expansion joints, we will put form and function together!



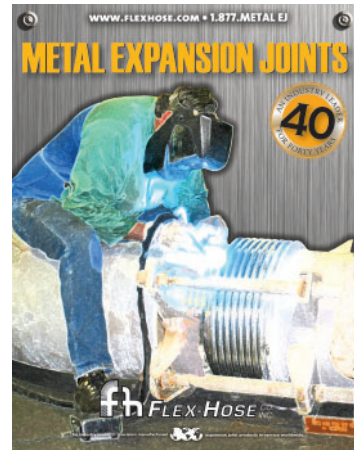

**Custom Designed Expansion Joints**

**Custom Designed Expansion Joints**

CUSTOM DESIGNED expansion joints (see page 30) can solve difficult performance problems which are not adaptable to standard designs. Field experience since 1968 has provided Flex-Hose Co. personnel with the necessary expertise to incorporate design materials improving your overall performance and reliability. Flex-Hose Co. expansion joints are engineered and manufactured for a broad range of requirements. They have been used in some of the most demanding applications worldwide. They are capable of isolating critical mechanical equipment from a piping or duct work system, thermal growth, dampen vibration, and reduce noise. Let us assist you on your next custom expansion joint. We look forward to meeting your performance expectations.

**Sizes  
2" to 60" I.D.**



**Flexcomp™ Expansion Compensators**

FLEXCOMP expansion compensator's (see page 14) compact design saves valuable space. It is a perfect way to absorb up to 2" of axial movement resulting from thermal growth in a domestic hot water, heating hot water, and chilled water piping system. Flexcomp's externally pressurized, rugged construction fully encases the stainless steel bellows with an external cover, assuring safety and reliability. Standard pressure ratings up to 200 psi. Flexcomps are available standard with female copper tube ends and steel male NPT ends.

**Standard Sizes  
¾" to 4" I.D.**

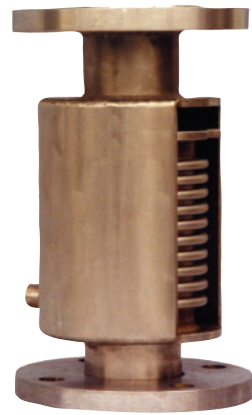

**Flexpress™ Externally Pressurized Guided Expansion Joints**

Flex-Hose Co.'s FLEXPRESS externally pressurized guided expansion joint (see page 16) provides a reliable means of absorbing high axial motions up to 16". Flexpress offers a totally enclosed, externally pressurized stainless steel bellows that is protected from external damage by an external cover. The rugged construction of the external cover is also designed for the working pressure. The Flexpress carbon steel pipe integral liner is designed to prevent bellows impingement or fatigue due to flow induced vibration. Standard pressure ratings up to 300 PSI are available with flanged ends or beveled weld ends.

**Standard Sizes  
2" to 24" I.D.**



**Bellowsflex™ Metal Bellows Expansion Joints**

BELLOWSFLEX metal bellows type expansion joints (see page 22) are designed for a wide range of service conditions. The standard bellows element is manufactured with 321 stainless steel. Other stainless steel or heat and corrosion resistant alloys are available. Standard pressure ratings up to 300 PSI. Available with flanged or beveled weld end fittings. Bellowsflex can also be supplied with accessories such as tie rods, flow liners, and protective external covers/shrouds.

**Sizes  
2" to 60" I.D.**

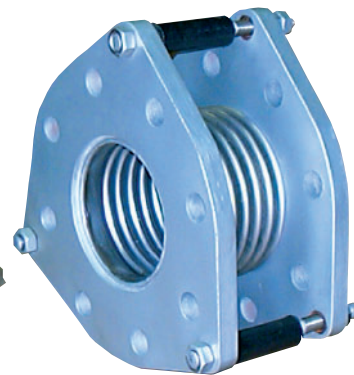

**Pumpflex™ Bellows Pump Connectors/Expansion Joints**

PUMPFLEX bellows pump connector (see page 24) features a 304 series stainless steel bellows construction. Pumpflex has a short face-to-face dimension for compact installations. It is ideal in applications for vibration control and noise reduction as well as strain relief, misalignment, and less than .5" movement of thermal growth. Pumpflex features tie rod restraints to prevent elongation, and compression sleeves to prevent over compression. Standard pressure ratings of 225 PSI. Available with 150 lb. flat face flanges. Additional alloys and styles available. Please consult factory.

**Standard Sizes  
2" to 24" I.D.**

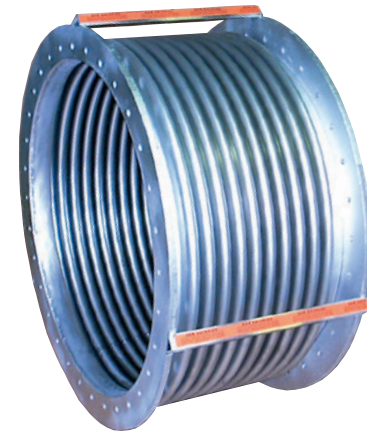

**BellowsXhaust™ Exhaust Type Expansion Joints**

BELLOWSXHAUST expansion joints (see page 26) are designed to absorb pipe expansion, reduce noise, and dampen vibration. They are ideal for low pressure (50 psi) and high temperature (1200°F) applications. The assembly weights have been reduced to permit use in thin wall flue duct systems. Most common applications are exhaust connections on diesel, gasoline or gas turbine engine installations, and ducting conveying corrosive gases. To simplify selection, standard designs have been developed with a 321 stainless steel bellows element. BellowsXhaust are available with flanged ends, weld ends and optional vanstone flanges with optional axial travel up to 3.5 inches.

**Standard Sizes  
4" to 48" I.D.**



**Guideline™ Pipe/Tube Alignment Guides**

GUIDELINE pipe alignment guides (see page 28) are designed to maintain the longitudinal position of the pipe's centerlines without causing axial restraint. Proper pipe guiding is vital for safe operation of piping systems incorporating the use of expansion joints or mechanical hard pipe loops when guiding pipe axial is essential. The use of traditional pipe supports (rollers, clevis hangers and U-bolts) do not assure the pipe is guided axially. Guideline assures safety of your expansion joints. Sizing is determined by the pipe size, axial movement and the amount of pipe insulation to be used. Copper tube guides are supplied with dielectric spacers to prevent galvanic corrosion. The two piece inside spider and two piece guiding sleeve of the Guideline provide easy bolt on installation.

**Standard Sizes  
½" to 24" I.D.**

**Contents:**

Thermal Movement.....6  
 Thermal Growth Chart.....7  
 High Corrugation vs. Low Corrugation .....8  
 Design Basics .....9  
 Accessories.....9  
 Movement Capabilities .....10  
 Design Considerations .....11  
 Glossary of Terms .....12  
 Custom Joints.....14  
 Flexcomp.....16  
 Flexpress .....18  
 Bellowsflex .....24  
 Pumpflex .....26  
 Bellows Xhaust .....28  
 Guideline.....30

## Thermal Movement

All materials **expand** and **contract** due to temperature changes. In a piping or ducting system, these thermal changes can produce stress on the system at fixed points such as vessels and rotating equipment as well as the piping or duct work system itself.

### Thermal changes are produced by the following:

- The temperature of the system when installed is different from operating temperature.  
*For example: chilled water, 100°F when installed, operates at 40°F*
- The temperature cycle during operation
- The system is exposed to ambient temperature changes

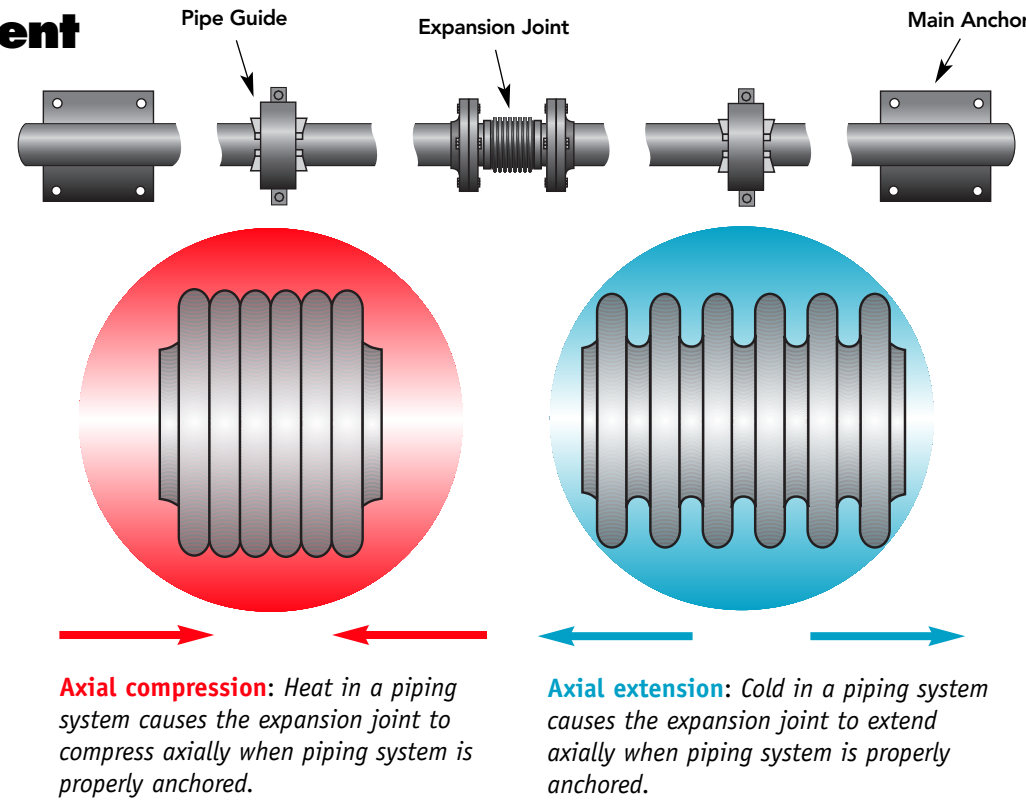

**Note: 80/20 Rule: 80% motion compression/20% extension.**  
 Example: Expansion joints rated for 3" total axial travel = 2.40 axial compression/.60 axial extension

## Compensating for Thermal Movement

The basic methods of compensating for thermal movement in a piping system are:

- Design a flexible piping system which utilizes changes of direction to absorb movement *For example: "Z" bends, "L" bends and mechanical pipe loops*
- Design expansion devices, expansion joints or flexible loop technology

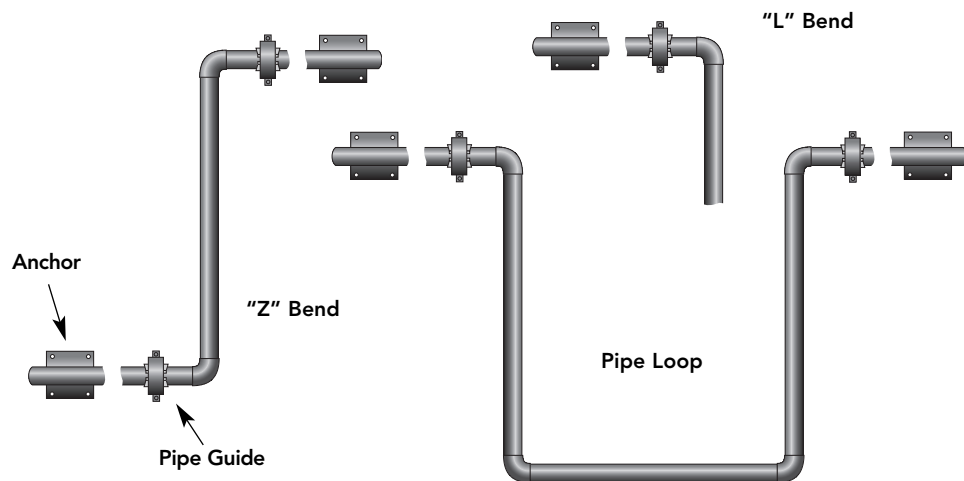

### Why Expansion Joints?

- Flex-Hose can assist with product selection, layout & design
- Inline, compact design saves valuable space reducing welding & other labor costs
- Ability to handle large amounts of axial expansion with one device vs. multiple devices

### Pipe bends and loops:

- Proper design requires accurate calculations for contraction, expansion & anchor loads
- Requires minimum lengths of offsets
- Pipe guides are essential
- May require more piping & labor costs
- May add to heat/friction lost & operating cost
- Require large space to install & may need multiple locations.

## Thermal Expansion of Metal Pipe

Linear Thermal Expansion, in/100 ft.				
Saturated Steam Pressure, psig	Temperature °F	Carbon Steel	Copper	Type 304 Stainless Steel
	-30	-0.19	-0.32	-0.30
	-20	-0.12	-0.21	-0.20
	-10	-0.06	-0.11	-0.10
	0	0	0	0
	10	0.08	0.12	0.11
	20	0.15	0.24	0.22
	32	0.24	0.37	0.36
	40	0.30	0.45	0.45
	50	0.38	0.57	0.56
	60	0.46	0.68	0.67
	70	0.53	0.79	0.78
	80	0.61	0.90	0.90
	90	0.68	1.02	1.01
	100	0.76	1.13	1.12
	120	0.91	1.37	1.35
	140	1.06	1.59	1.57
	160	1.22	1.80	1.79
	180	1.37	2.05	2.02
	200	1.52	2.30	2.24
	212	1.62	2.38	2.43
	220	1.69	2.52	2.48
	240	1.85	2.76	2.71
	260	2.02	2.99	2.94
	280	2.18	3.22	3.17
	300	2.35	3.46	3.40
	320	2.53	3.70	3.64
	340	2.70	3.94	3.88
	360	2.88	4.18	4.11
	380	3.05	4.42	4.35
	400	3.23	4.87	4.59
	500	4.15	5.91	5.80
	600	5.13	7.18	7.03
	700	6.16	8.47	8.29
	800	7.23	9.79	9.59
	900	8.34	11.16	10.91
	1000	9.42	12.54	12.27

### Calculating Pipe Growth

*Application:*  
Heating Hot Water

*Example:*  
A 2" copper pipe line is 134 feet long. Maximum temperature the line will encounter is 200°F. Lowest temperature is 40°F.

*Calculation:*  
From chart – the expansion of copper pipe at:  
 200°F 2.30" per 100 ft. pipe  
 40°F .45" per 100 ft. pipe  
 Difference 1.85" per 100 ft. pipe  
 134/100 x 1.85 = 2.48" total length change

*Application:*  
110# Steam

*Example:*  
A 6" steel pipe line is 152 feet long. Maximum temperature the line will encounter is 340°F. Lowest ambient temperature is -20°F.

*Calculation:*  
From chart – the expansion of steel pipe at:  
 340°F 2.70" per 100 ft. pipe  
 -20°F .12" per 100 ft. pipe  
 Total 2.82" per 100 ft. pipe  
 152/100 x 2.82 = 4.29" total length change

### Thermal Expansion and Contraction

Application	Temperature Range (°F)	Thermal Expansion (per 100 ft.)
Chilled Water	40° - 100°	.46"
Condenser Water	40° - 100°	.46"
Domestic Hot Water (Copper Pipe)	40° - 140°	1.14"
Hot Water	40° - 200°	1.22"
Steam 100 psig	40° - 338°	2.40"



## The evolution of bellows technology

### Flex-Hose State-of-the-Art Technology - Low Corrugation

Flex-Hose Co. state-of-the-art low corrugation technology (Figure A) reduces the corrugation height and pitch. This limits the pressure stresses on the corrugations cross section. The low profile design incorporates the correct number of convolutions to achieve the desired movement of the bellows. The smaller outer diameter also saves valuable space. Over 60 percent smaller effective area of the bellows substantially reduces the size of the anchors, the structure to which the pipe guides are attached, and lowering the overall cost while simplifying installation.

### Old Technology - High Corrugation

High corrugation (Figure B) is old technology. It must use reinforcing rings to achieve higher working pressure over 50 psi. The extreme height and pitch of the convolutions cause the expansion joint to have very little hoop strength, requiring external structure such as root rings or reinforcing rings for pressures greater than 50 spi.

The increased effective area of the bellows significantly increases the over all cost of a project by creating the need for larger anchors and structure to attach the pipe guides to.

### Low Corrugation vs. High Corrugation

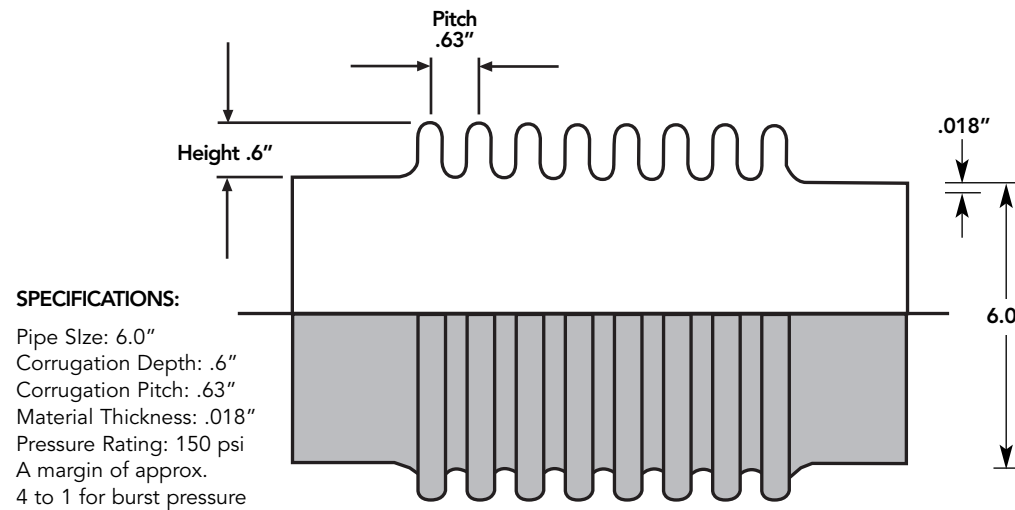

By reducing the corrugation height and pitch, we limit the pressure stresses on the corrugation cross-section. The low profile design incorporates the correct number of convolutions to achieve the desired movement of the bellows.

#### FEATURES:

- No ring reinforcement required
- Lower rod and hinge hardware costs
- Over 60% smaller effective area reduces anchoring costs
- Extension allowance normally eliminates precompression at installation site
- Lighter weights reduce shipping costs and simplify installation

Figure A. - Low Corrugation

State-of-the art low corrugation expansion joint would have an effective area of 34.5 in<sup>2</sup>.  
 Pressure thrust force = (150 psig)(34.5 in<sup>2</sup>) = 5176 lbs.

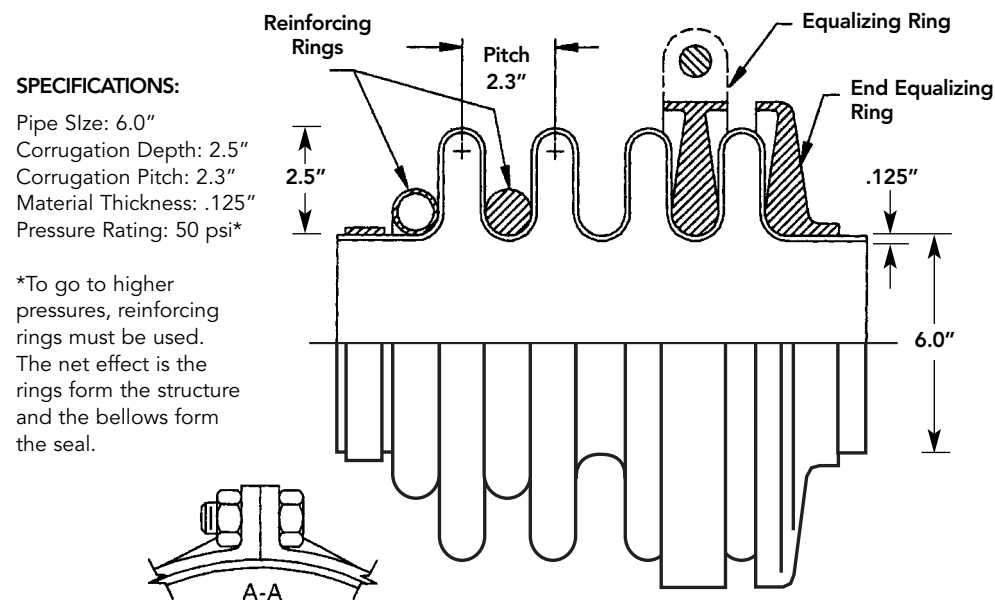

Figure B. - High Corrugation

High corrugation expansion joint would have an effective area of 56.7 in<sup>2</sup>.  
 Pressure thrust force = (150 psig)(56.7 in<sup>2</sup>) = 8505 lbs.

## Bellows Design Basics

Flex-Hose Co. metal expansion joints are designed for a wide range of service conditions. They consist of a flexible bellows element, appropriate end fittings to match adjoining pipe fittings and schedule. The bellows is a flexible seal design to contain the media, absorb thermal movement, and pressures of the system.

The bellows are manufactured from thin-walled tubing to form a corrugated cylinder. The corrugations are commonly referred to as convolutions and add the structure necessary for the bellows material to contain system pressure.

The bellows design incorporates the thickness and convolution geometry that meets the capacity of the adjoining pipe to contain system pressure at the specified design temperature.

Flexibility of the bellows is achieved through the convolution profile and pitch as multiple convolutions are required to provide the expected expansion and contraction of the piping system.

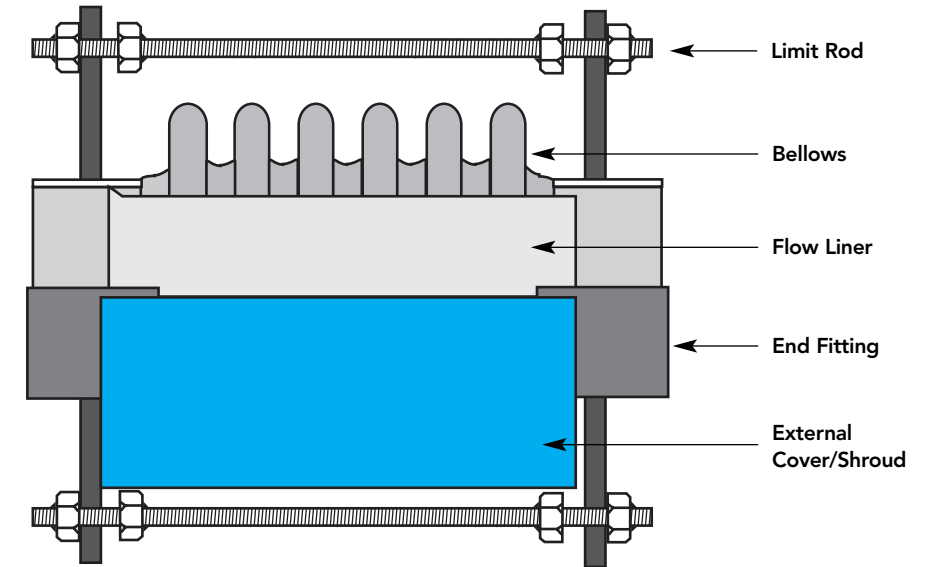

### Accessories

#### Covers

Expansion joints require careful handling and must be protected from any impact, weld spatter, etc. Before insulating an expansion joint, care must be taken that foreign material is not trapped in the corrugations impeding its movements. It is suitable to install a metal cover over the flanges and then wrap the insulation around it.

#### Flow Liners

Flow liners are installed in the inlet bore of the expansion joint to protect the bellows from erosion damage due to abrasive media or resonant vibration caused by turbulent flow or excessive velocities.

#### Tie Rods

Tie Rods are devices with the primary function to restrain the bellows pressure thrust. It should be pointed out that when tie rods are furnished on expansion joints

subject to external axial movement, they will only restrain the pressure thrust in the event of an anchor failure. During normal operation the anchor or adjacent equipment will be subjected to the pressure thrust forces.

#### Limit Rods

Limit Rods are devices with the primary function of restricting the bellows movement range. The limit rods are designed to prevent bellows over-extension or over-compression while restraining the full pressure thrust in the event of a main anchor failure.

#### Control Rods

Control Rods are devices attached to the expansion joint with the primary function of distributing movement between the two bellows of a universal joint. Control rods are not designed to restrain bellows pressure thrust.

## Expansion Joint Movement Capabilities

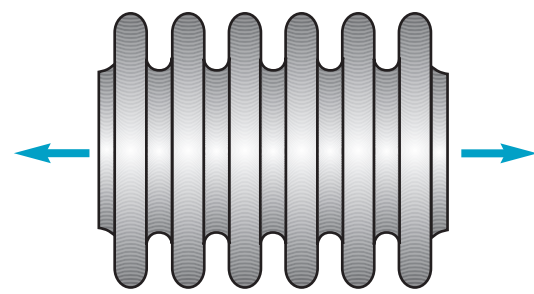

### AXIAL EXTENSION

Extension of the bellows length due to pipe contraction when piping system is anchored properly.

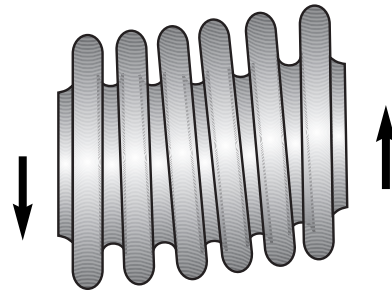

### LATERAL OFFSET

Motion which is perpendicular to the plane of the pipe with the expansion joint fittings remaining parallel.

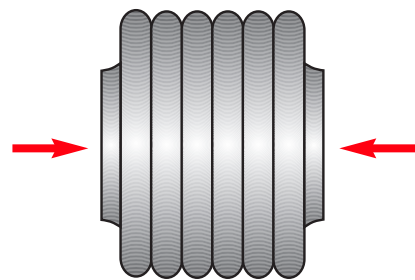

### AXIAL COMPRESSION

Compression of the bellows length due to pipe expansion when piping system is anchored properly.

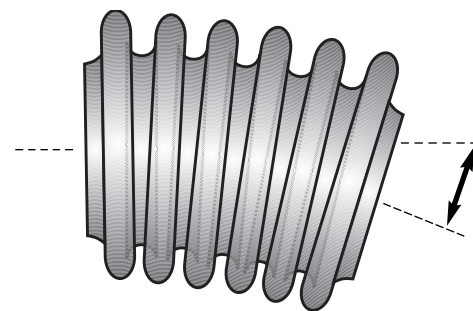

### ANGULAR ROTATION

Bending about the longitudinal centerline of the expansion joint.

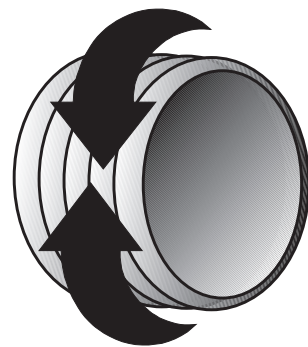

### TORSION

Bending about the longitudinal centerline of the expansion joint

### Installation Misalignment

Misalignment of the expansion joint on installation reduces the total movement capacity of an expansion joint. Misalignment of the piping system should be corrected prior to installation of the expansion joint. If the misalignment can not be corrected, please contact Flex-Hose Co. for technical support.

### Concurrent Movements

Expansion joint movement capacity published in the catalog is maximum capacity for non-current movement. Axial, lateral, and angular movements can occur simultaneously, i.e. on reactor vessels or piping systems utilizing expansion joints at building/seismic interfaces. If your application involves concurrent motions it is essential that the movement capacity of the expansion joint be determined. The sum of these values may not exceed 100%.

For example:

#### Expansion Joint design parameters

##### Non-concurrent

Axial	1.5"
Lateral	.50"
Angular	10°

##### Concurrent

Axial	.75"	=	50%
Lateral	.125"	=	25%
Angular	2.5°	=	25%
<b>TOTAL</b>		=	<b>100%</b>

## Expansion Joint Design Considerations

We have noted how placing a flexible metal bellows at selected locations in a piping system can accommodate its thermal growth. There are some side effects which occur when a pipe is cut in two and a bellows is inserted to take up the movement of the pipe. The side effects are pressure thrust or spring rate. It is essential for proper anchor designs to determine which one will impact your design.

### Spring Rate

In very low pressure application the more significant force may be the spring rate (force to compress the bellows) which is expressed in pounds per inch of motion. Thus, as the pipe grows due to increasing temperature, the bellows will resist compression by the force noted in the spring rate (Figure A).

A comparison of pressure and force data to spring rate will show that it does not require very much line pressure for pressure thrust to be the dominant factor of the two in expansion joint applications.

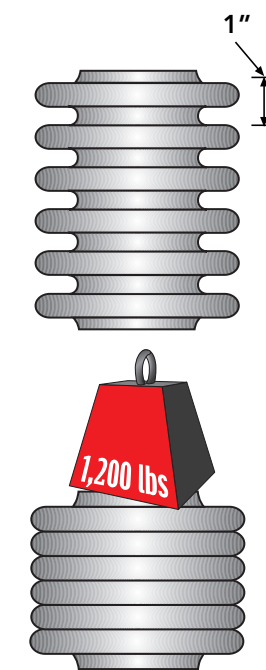

Figure A.

### Pressure Thrust

The bellows' very nature of being flexible (to absorb movement) will extend (straighten out) due to the line pressure (Figure B). This pressure thrust must then be absorbed by some means or the line pressure will cause the bellows to over extend and tear itself apart. This force may be accommodated by anchoring the pipe or by using an expansion joint which incorporates tie rods or limit rods.

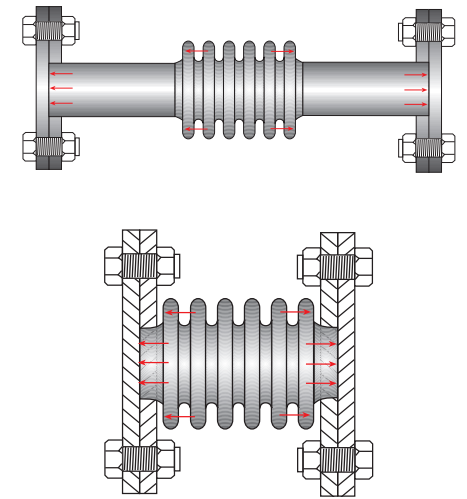

Figure B. Pressure Thrust For example, see page 8.

### Squirm

Convolutions can be added to increase movement without sacrificing cycle life, but there is a limit to this process which is reached when the bellows, under internal pressure, exhibits a condition known as squirm (bellows instability). (Figure C).

Externally pressurized bellows are not subject to this condition, as they become

more stable under pressure. A bellows is a flexible seal. This convoluted part of the expansion joint is designed to flex when thermal movement in the piping system occurs. Therefore, by determining the thermal movements that will occur in the piping system, expansion joints may be specified, manufactured, and installed in the system to accommodate these movements.

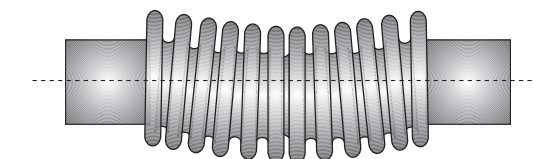

Figure C. Squirm/Bellows Instability

### WARNING

**TORSION:** Twisting about the longitudinal axis of a metal expansion joint will reduce bellows life or cause expansion joint failure and should be avoided. Expansion joints should not be located at any point in a piping system that would impose torque to the expansion joint device.



## Expansion Joint Glossary of Terms

### Angular Rotation

Bending about the longitudinal centerline of the expansion joint.

### Axial Extension

Extension of the bellows length due to pipe contraction when piping system is anchored properly.

### Axial Compression

Compression of the bellows length due to pipe expansion when piping system is anchored properly.

### Bellows

The flexible element of an expansion joint consisting of one or more convolutions.

### Bellows Expansion Joint

Any device containing one or more bellows used to absorb directional changes, such as those caused by thermal expansion or contraction of a pipeline, duct or vessel.

### Concurrent Movement

Simultaneous movement axially, laterally and angularly.

### Control Rod

Devices attached to the expansion joint with the primary function of distributing movement between the two bellows of a universal joint.

### Convolution or Corrugation

The smallest flexible unit of a bellows, with total movement of a bellows being proportional to the number of convolutions.

### Cycle

A cycle is one complete movement from initial position to operating position and back.

### Cycle Life

Also known as fatigue life expectancy, is affected by various factors including (but not limited to): operating pressure, operating temperature, bellows material, and bellows design/profile. Change to any of these factors will change cycle life.

### Directional Anchor

A directional anchor, or sliding anchor, is one which is designed to absorb loads in one direction while permitting motion in another. It may be either a main or intermediate anchor, depending upon the application considered. When designing a directional anchor, an effort should be made to minimize the friction between its moving or sliding parts, since this will reduce the loading on the pipe and equipment, and will ensure proper function of the anchor.

### External Cover/Shroud

Expansion joints require careful handling and must be protected from any impact, weld spatter, etc. Before insulating an expansion joint, care must be taken that foreign material is not trapped in the corrugations. It is suitable to install a metal cover over the flanges and then wrap the insulation around it.

### Flow Liner

Installed in the inlet bore of the expansion joint to protect the bellows from erosion damage due to abrasive media or resonant vibration due to turbulent flow or excessive velocities.

### Intermediate Anchor

An intermediate anchor is one which divides a pipeline into individual expanding pipe sections containing multiple expansion devices of the same pipe size. Such an anchor must be designed to withstand the forces and moments imposed upon it by each of the pipe sections to which it is attached. In the case of a pipe section containing one or more bellows units, these forces will consist of forces and/or moments required to deflect the bellows unit plus the frictional forces due to the pipe moving over its guides. The pressure thrust is absorbed by the other anchors or devices on the bellows unit such as limit rods, tie rods, hinged restraints, etc.

### Lateral Offset

Motion which is perpendicular to the plane of the pipe with the expansion joint fittings remaining parallel.

### Limit Rod

Devices with the primary function of restricting the bellows movement range. The limit rods are designed to prevent bellows over-extension or over-compression while restraining the full pressure thrust in the event of a main anchor failure.

### Main Anchor

A main anchor is one installed at any of the following locations in a pipe system containing one or more bellows:

- 1) At a change in direction of flow
- 2) Between two bellows units of different size installed in the same straight run
- 3) At the entrance of a side branch onto the main line
- 4) Where a shut-off or pressure-reducing valve is installed in a pipe run between two bellows units
- 5) At a capped end of pipe

A main anchor must be designed to withstand the forces and moments imposed upon it by each of the pipe sections to which it is attached. In the case of a pipe section containing an unrestrained bellows, these will consist of the pressure thrust, the force required to deflect the bellows unit, and the frictional force due to the pipe moving over its guides.

### Pipe Alignment Guide

A pipe alignment guide is a form of sleeve fastened to some rigid part of the installation which permits the pipeline to move freely in only one direction, i.e. along the axis of the pipe. Pipe alignment guides are designed primarily for use in applications involving axial movement only.

### Pipe Support

A pipe support is any device which permits free movement of the piping and carries the total weight of in line equipment such as valves, meters, expansion joints, and the weight of the contained fluid. Pipe supports cannot be substituted for pipe alignment guides. Pipe rings, U-bolts, roller supports, and spring hangers are some examples of conventional pipe supports.

### Planar Guide

A directional pipe planar guide is a pipe alignment guide modified to permit limited movement and/or bending of the pipe in one plane. It is used only in applications involving lateral deflection or angular rotation resulting from 2- or 3-hinge piping configurations.

### Pressure Thrust

Extension of the bellows due to line pressure. This pressure thrust must then be absorbed by some means or the line

pressure will cause the bellows to over extend and tear itself apart.

### Spring Rate

In very low pressure application the more significant force may be the spring rate which is expressed in pounds per inch of motion. Thus, as the pipe grows due to increasing temperature, the bellows will resist compression by the force noted in the spring rate.

### Squirm

Strut instability caused by internal pressure on the bellows.

### Thermal Movement

Expansion and contraction due to temperature changes. In a piping or ducting system, these thermal changes can produce stress on the system at fixed points such as vessels and rotating equipment as well as the piping or duct work system itself.

### Tie Rod

Devices with the primary function to restrain the bellows pressure thrust.

### Torsion

Twisting about the longitudinal axis of a metal expansion joint when it is located at any point in a piping system that would impose torque as a result of thermal change or building seismic joints imposing torque.



The industry leader in precision manufactured  expansion joint products in-service worldwide.

# CUSTOM DESIGNED METAL EXPANSION JOINTS



**New installation or replacements**

**Available with Flow Liner and Protective Cover/Shroud**

**Available for 150, 300 and 600 psi Service**

**Available sizes 2" to 60"**



CSA standard B-51 certified. Inspected and tested by the Technical Standards and Safety Authority of Canada.

## We'll custom build metal expansion joints to fit your application or refurbish your current ones!

Flex-Hose Co.'s custom metal expansion joints can solve difficult performance problems which are not adaptable to standard designs. Field experience since 1968 has provided Flex-Hose Co., Inc. personnel with the necessary expertise to improve your overall performance and reliability.

Flex-Hose Co.'s metal expansion joints are engineered and manufactured to accommodate a broad range of service conditions. They have been used in some of the most demanding applications worldwide and are capable of isolating critical mechanical equipment from piping or duct work systems, thermal growth, vibration and noise reduction.

Let us assist you on your next custom metal expansion joint application. We look forward to meeting your performance expectations.

## LET US ASSIST YOU ON YOUR NEXT CUSTOM METAL EXPANSION JOINT!



**Custom Designed Joint:** 30" nominal ID x 36" Fx F, expansion joint with stainless steel liner. Custom elliptical steel flanges, 35" x 50 Fx F" with control rods. Design 150 psi @ 650°F

### TAKE CONTROL OF YOUR CUSTOM PROJECT WITH OUR CUTTING-EDGE XJS DESIGN SOFTWARE!

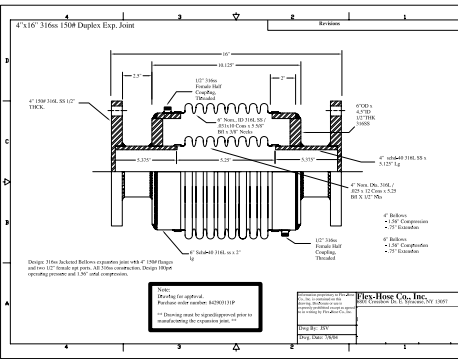

- SAVES DESIGN TIME!
- Calculates pipe expansion
- Input design criteria
- Computes engineering calculations
- Calculates anchor loads
- Produces pipe guide layout
- Verifies design to EJMA (Expansion Joint Manufacturer's Assn)
- Creates detailed submittal drawings

**IT'S FREE!**

Available at [www.flexhose.com](http://www.flexhose.com)



**Custom Designed Joint:** 16"x13 1/4" Fx F, 321 stainless steel bellows and flow liner, 150# flanges with control rods and exterior shroud. Design 150 psi @ 600°F for 2" axial compression.

**SAVE COST!** Let us refurbish your custom expansion joints.

20" Universal tied expansion joint being rebuilt with radiograph bellows.

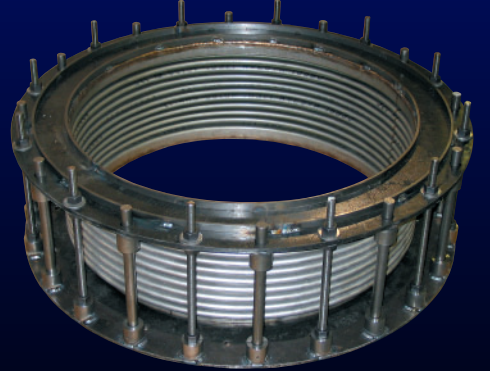
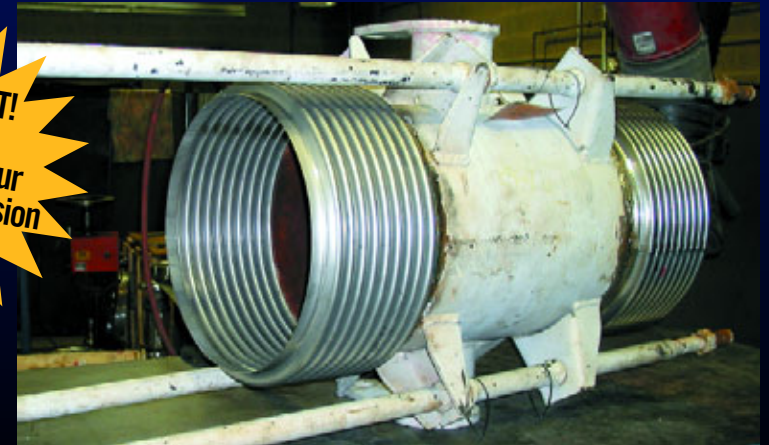

**Custom Designed Joint:** 30"x14", 316 stainless steel bellows with custom 3 1/2" O.D. carbon steel flanges with groove for carbon sealing ring. Design 1 psi @ 200°F for 2 1/2" of axial compression.



Large Inventory for Immediate Shipment!



# Flexcomp™

FLEXCOMP expansion compensators compact design saves valuable space. It is a perfect way to absorb up to 2" of axial movement resulting from thermal growth in a domestic hot water, heating hot water and chilled water piping system.

Flexcomp's externally pressurized, rugged construction fully encases the stainless steel bellows with an external cover, assuring safety and reliability. The integral liner is designed to prevent bellows impingement or fatigue due to flow reduced vibration.

Standard working pressure ratings up to 200 psi. Maximum system test pressure 300 psi. Flexcomps are available standard with female copper tube ends and steel male NPT ends.

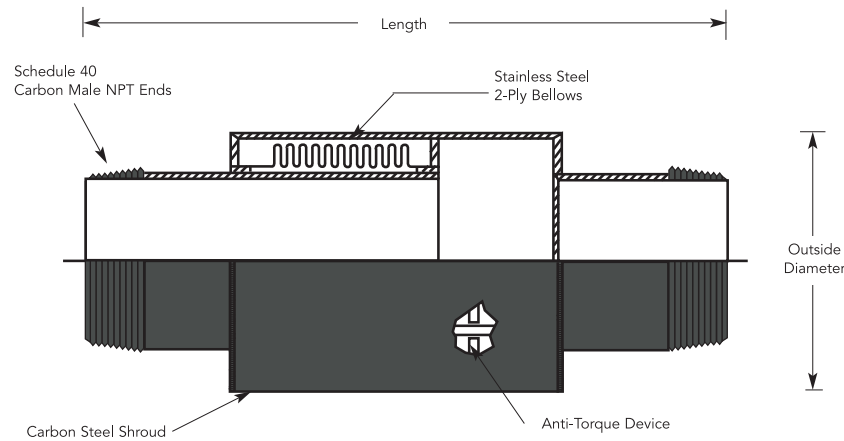

### HP/STL-MxM

NOTE: Also available with flanges (HP/STL-FxF).

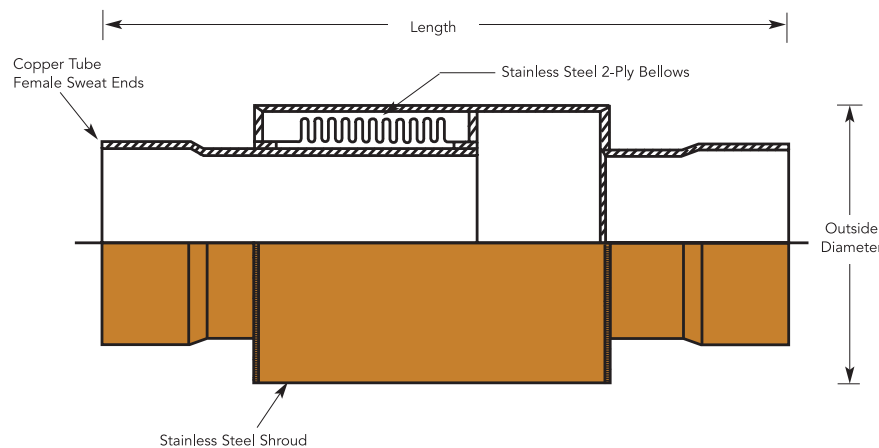

### HP/CPR-FSxFS

 CSA standard B-51 certified. Inspected and tested by the Technical Standards and Safety Authority of Canada.



## HP/STL-MxM Steel Piping Systems

I.D. (In.)	Length (In.)	Max Pressure (PSI)		Movement Capability		Weight (Lbs.)
		Working	Test	Compression (In.)	Extension (In.)	
.75	12.125	200	300	1.75	.25	5.50
1.00	12.125	200	300	1.75	.25	7.00
1.25	14.125	200	300	1.75	.25	10.20
1.50	14.125	200	300	1.75	.25	12.30
2.00	14.125	200	300	1.75	.25	13.20
2.50	15.500	200	300	1.75	.25	19.60
3.00	15.187	200	300	1.75	.25	24.40
4.00	15.187	200	300	1.75	.25	27.50

## HP/CPR-FSxFS Copper Piping Systems

I.D. (In.)	Length (In.)	Max Pressure (PSI)		Movement Capability		Weight (Lbs.)
		Working	Test	Compression (In.)	Extension (In.)	
.75	12.500	200	300	1.75	.25	2.20
1.00	12.500	200	300	1.75	.25	2.40
1.25	13.812	200	300	1.75	.25	3.10
1.50	13.812	200	300	1.75	.25	3.30
2.00	13.812	200	300	1.75	.25	5.50
2.50	14.435	200	300	1.75	.25	7.50
3.00	14.435	200	300	1.75	.25	10.00

### Standard Sizes 3/4" to 4" I.D.

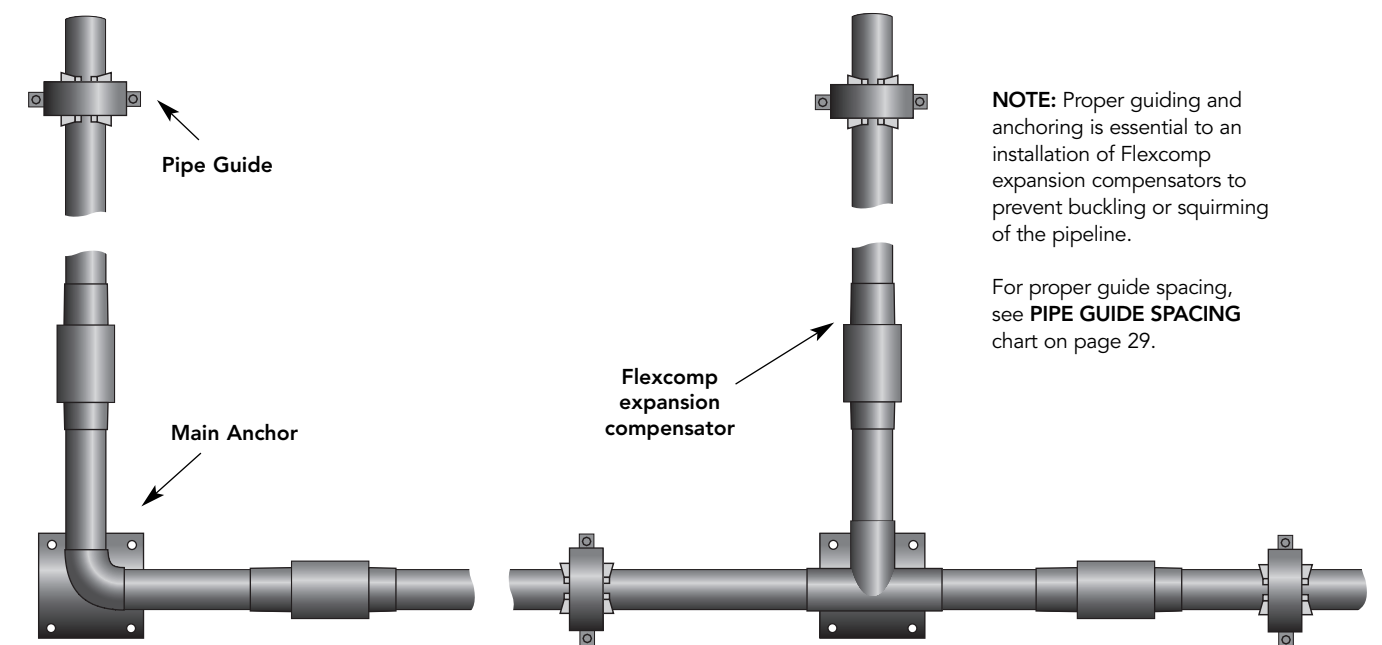

### Typical Flexcomp Installation



# Flexpress™

## Flexpress FPS-Single

### For up to 8" of movement

Flex-Hose Co.'s FLEXPRESS externally pressurized guided expansion joint provides a reliable means of absorbing high axial motions up to 8". Flexpress offers a totally enclosed, externally pressurized stainless steel bellows that is protected from external damage by an external cover. The rugged construction of the external cover is also designed for the working pressure. The Flexpress carbon steel pipe integral liner is designed to prevent bellows impingement or fatigue due to flow induced vibration. Standard drain port allows convenient removal of condensation and sediment in steam service applications. Another important design feature of the Flexpress is the internal guide ring which maintains the longitudinal centerline of the expansion joint and eliminates the first set of pipe guides required (4 pipe dia.) on each side of the Flexpress saving material and labor. Standard pressure ratings up to 300 PSI. Maximum test pressure 1.5 times maximum working pressure. Available with flanged ends or beveled weld ends.

### Standard Sizes 2" to 24" I.D.

Additional sizes available. Please consult factory.

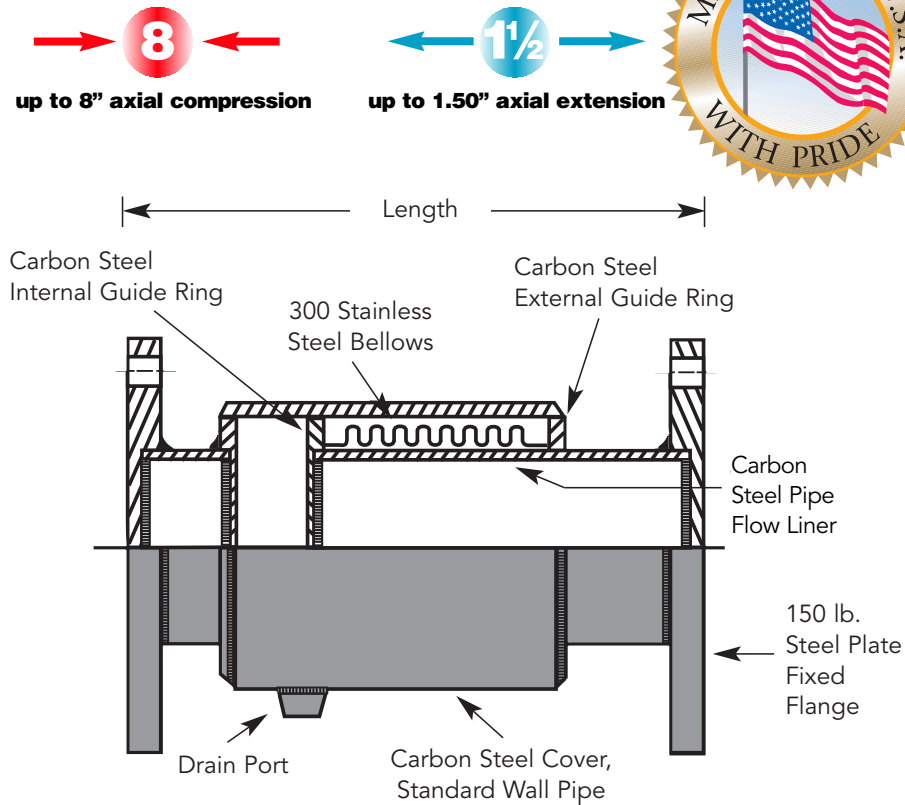

**Flexpress FPS/FxF  
(Flanged Ends)**

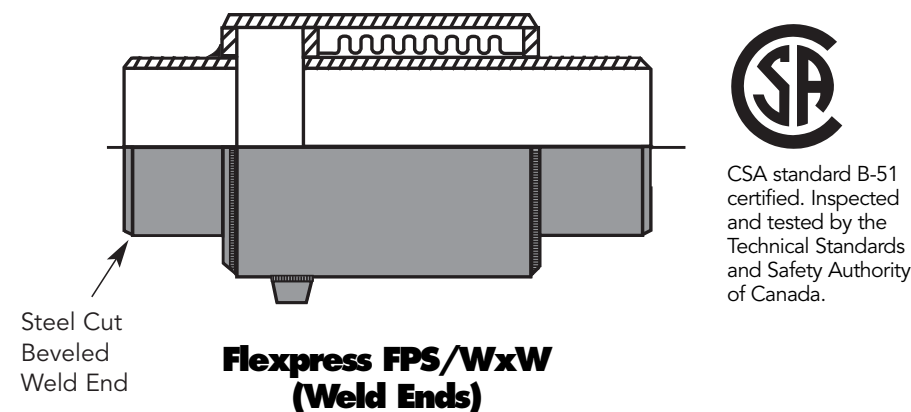

**Flexpress FPS/WxW  
(Weld Ends)**

**SA**  
CSA standard B-51 certified. Inspected and tested by the Technical Standards and Safety Authority of Canada.



## Flexpress FPD-Dual

### For up to 16" of movement

Flex-Hose Co.'s FLEXPRESS externally pressurized guided dual expansion joint provides a reliable means of absorbing high axial motions up to 16". Flexpress dual expansion joint incorporates an intermediate anchor base to simplify installations and reduce labor cost. Flexpress offers a totally enclosed, externally pressurized stainless steel bellows that is protected from external damage by an external cover. The rugged construction of the external cover is also designed for the working pressure. The Flexpress carbon steel pipe integral liner is designed to prevent bellows impingement or fatigue due to flow induced vibration. Standard pressure ratings up to 300 PSI. Maximum test pressure 1.5 times maximum working pressure. Available with flanged ends or beveled weld ends.

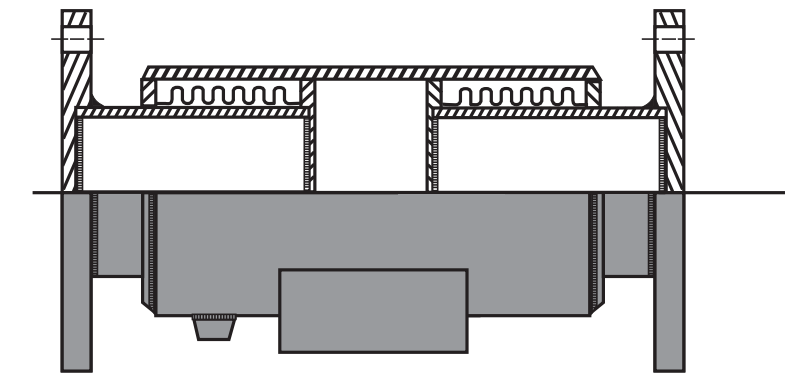

**Flexpress FPD/FxF  
(Flanged Ends)**

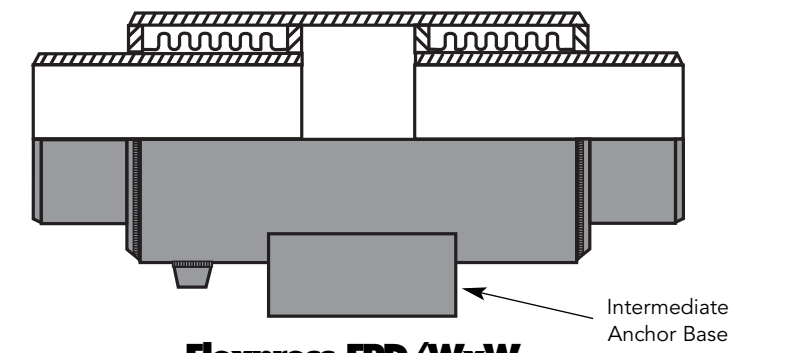

**Flexpress FPD/WxW  
(Weld Ends)**

Intermediate Anchor Base

### Standard Sizes 2" to 24" I.D.



CSA standard B-51 certified. Inspected and tested by the Technical Standards and Safety Authority of Canada.

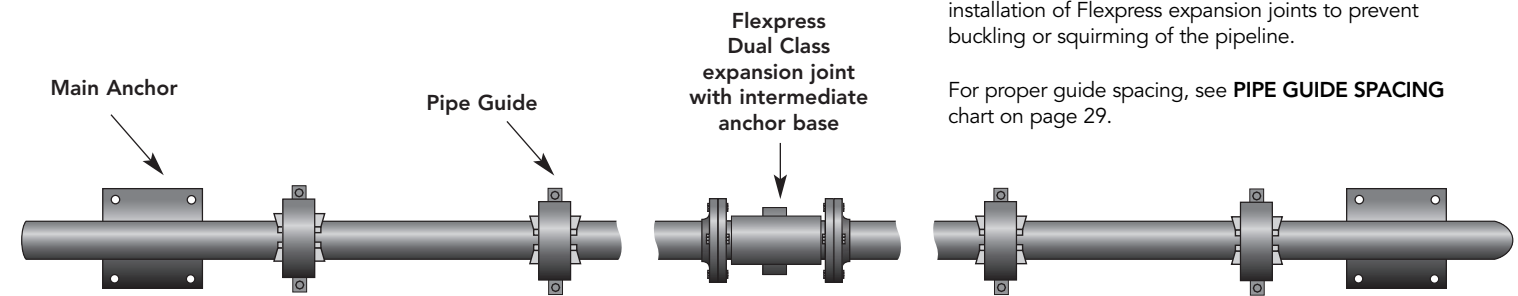
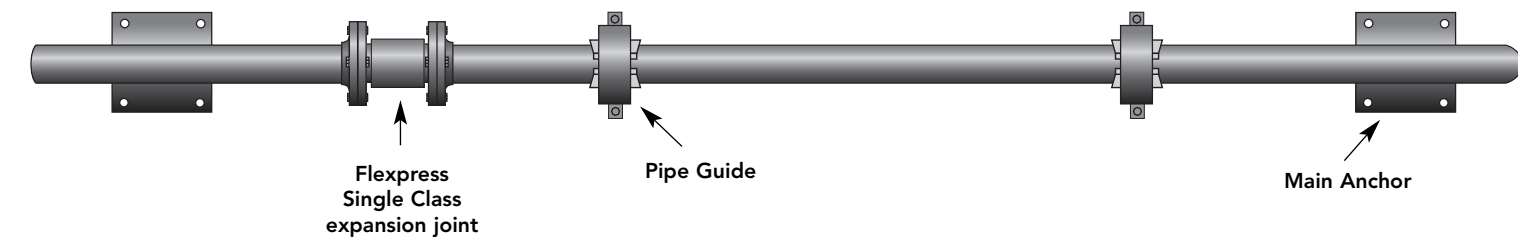

**NOTE:** Proper guiding and anchoring is essential to an installation of Flexpress expansion joints to prevent buckling or squirming of the pipeline.

For proper guide spacing, see **PIPE GUIDE SPACING** chart on page 29.

## Typical Flexpress Installation



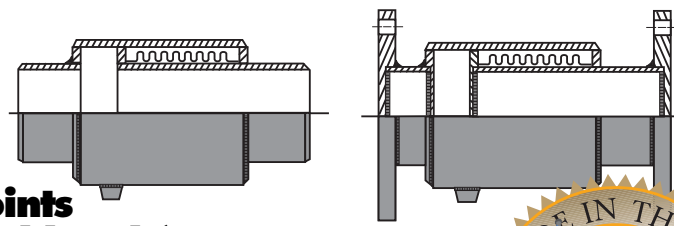

**150# Single Class Expansion Joints**  
**FxF (Flanged Ends) or WxW (Weld Ends)**  
 For up to 8" of movement

**Flexpress FPS-FxF150/FPS-WxW150**

**Design Pressure 150 PSIG • Test Pressure 225 PSIG**

I.D. (In.)	Bellows Area (Sq. In.)	Length (In.)		Movement Capability (In.)		Weight (Lbs.)	
		FP/150-FxF	FP/150-WxW	Compression	Extension	FP/150-FxF	FP/150-WxW
2.00	12	25.50	23.25	4.00	.75	44.00	33.00
		34.50	32.00	6.00	1.12	56.00	46.00
		41.50	39.25	8.00	1.50	65.00	55.00
2.50	12	25.50	23.25	4.00	.75	51.00	35.00
		34.50	32.00	6.00	1.12	65.00	50.00
		41.50	39.25	8.00	1.50	75.00	60.00
3.00	16	24.50	22.25	4.00	.75	63.00	46.00
		31.50	28.50	6.00	1.12	74.00	57.00
		39.50	37.25	8.00	1.50	91.00	74.00
4.00	30	25.75	22.75	4.00	.75	99.00	72.00
		32.50	29.50	6.00	1.12	117.00	89.00
		41.25	38.50	8.00	1.50	144.00	116.00
5.00	42	24.00	21.50	4.00	.75	128.00	95.00
		30.00	27.50	6.00	1.12	149.00	116.00
		36.25	33.75	8.00	1.50	171.00	138.00
6.00	53	24.00	21.50	4.00	.75	144.00	102.00
		30.25	27.50	6.00	1.12	167.00	125.00
		36.25	33.75	8.00	1.50	191.00	149.00
8.00	83	25.25	22.50	4.00	.75	228.00	161.00
		32.00	29.00	6.00	1.12	265.00	198.00
		38.50	35.75	8.00	1.50	302.00	236.00
10.00	135	26.75	23.75	4.00	1.00	306.00	209.00
		34.00	30.75	6.00	1.50	358.00	261.00
		43.25	40.00	8.00	2.00	434.00	337.00
12.00	182	28.00	24.50	4.00	1.00	400.00	257.00
		35.75	32.00	6.00	1.50	467.00	324.00
		45.25	41.75	8.00	2.00	562.00	419.00
14.00	212	28.25	24.50	4.00	.75	491.00	293.00
		36.00	32.00	6.00	1.12	565.00	367.00
		45.50	41.75	8.00	1.50	671.00	473.00
16.00	276	28.75	24.50	4.00	.75	547.00	329.00
		36.25	32.00	6.00	1.12	631.00	412.00
		46.00	41.75	8.00	1.50	749.00	530.00
18.00	338	29.00	24.50	4.00	.75	652.00	364.00
		36.50	32.00	6.00	1.12	745.00	456.00
		46.25	41.75	8.00	1.50	875.00	588.00
20.00	404	29.75	24.50	4.00	.75	766.00	400.00
		37.25	32.00	6.00	1.12	868.00	501.00
		47.00	41.75	8.00	1.50	1012.00	646.00
22.00	481	30.00	24.50	4.00	.75	848.00	436.00
		37.50	32.00	6.00	1.12	959.00	546.00
		47.25	41.75	8.00	1.50	1115.00	703.00
24.00	562	30.25	24.50	4.00	.75	961.00	472.00
		38.00	32.00	6.00	1.12	1081.00	590.00
		47.50	41.75	8.00	1.50	1250.00	761.00

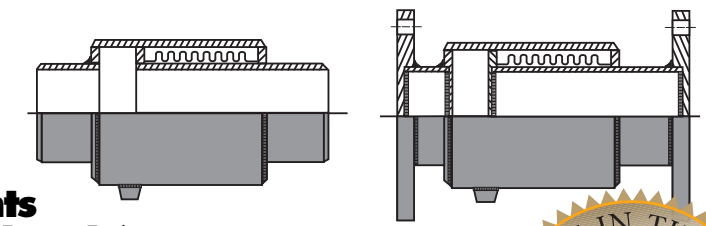

**300# Single Class Expansion Joints**  
**FxF (Flanged Ends) or WxW (Weld Ends)**  
 For up to 8" of movement

**Flexpress FPS-FxF300/FPS-WxW300**

**Design Pressure 300 PSIG • Test Pressure 450 PSIG**

I.D. (In.)	Bellows Area (Sq. In.)	Length (In.)		Movement Capability (In.)		Weight (Lbs.)	
		FP/300-FxF	FP/300-WxW	Compression	Extension	FP/300-FxF	FP/300-WxW
2.00	12	25.75	23.25	4.00	.75	49.00	35.00
		34.75	32.00	6.00	1.12	63.00	48.00
		41.75	39.25	8.00	1.50	72.00	58.00
2.50	12	25.75	23.25	4.00	.75	56.00	36.00
		34.75	32.00	6.00	1.12	73.00	52.00
		41.75	39.25	8.00	1.50	84.00	63.00
3.00	16	24.75	22.25	4.00	.75	75.00	47.00
		31.25	28.50	6.00	1.12	87.00	59.00
		39.75	37.25	8.00	1.50	106.00	78.00
4.00	30	25.75	22.75	4.00	.75	121.00	74.00
		32.50	29.50	6.00	1.12	141.00	94.00
		41.25	38.50	8.00	1.50	170.00	124.00
5.00	42	24.50	21.50	4.00	.75	158.00	97.00
		30.75	27.50	6.00	1.12	181.00	120.00
		36.75	33.75	8.00	1.50	203.00	143.00
6.00	53	25.25	21.50	4.00	.75	190.00	106.00
		31.25	27.50	6.00	1.12	214.00	130.00
		37.50	33.75	8.00	1.50	239.00	155.00
8.00	83	26.75	22.50	4.00	.75	295.00	168.00
		33.50	29.00	6.00	1.12	336.00	209.00
		40.00	35.75	8.00	1.50	377.00	250.00
10.00	135	28.50	23.75	4.00	1.00	396.00	216.00
		35.75	30.75	6.00	1.50	452.00	272.00
		44.75	40.00	8.00	2.00	534.00	354.00
12.00	182	30.50	24.50	4.00	1.00	540.00	285.00
		38.25	32.00	6.00	1.50	610.00	355.00
		47.75	41.75	8.00	2.00	712.00	457.00
14.00	212	30.75	25.00	4.00	.75	732.00	373.00
		38.50	32.50	6.00	1.12	828.00	468.00
		48.00	42.25	8.00	1.50	966.00	607.00
16.00	276	31.50	25.00	4.00	.75	798.00	418.00
		39.25	32.50	6.00	1.12	905.00	525.00
		48.75	42.25	8.00	1.50	1060.00	680.00
18.00	338	31.75	25.00	4.00	.75	1007.00	463.00
		39.50	32.50	6.00	1.12	1126.00	581.00
		49.00	42.25	8.00	1.50	1297.00	753.00
20.00	404	32.00	25.00	4.00	.75	1189.00	508.00
		39.75	32.50	6.00	1.12	1319.00	637.00
		49.25	42.25	8.00	1.50	1507.00	826.00
22.00	481	32.75	25.00	4.00	.75	1356.00	553.00
		40.50	32.50	6.00	1.12	1497.00	693.00
		50.00	42.25	8.00	1.50	1702.00	899.00
24.00	562	33.00	25.00	4.00	.75	1619.00	598.00
		40.75	32.50	6.00	1.12	1772.00	750.00
		50.25	42.25	8.00	1.50	1993.00	972.00



CSA standard B-51 certified. Inspected and tested by the Technical Standards and Safety Authority of Canada.



CSA standard B-51 certified. Inspected and tested by the Technical Standards and Safety Authority of Canada.



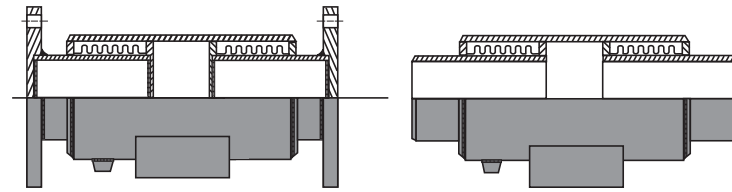

**150# Dual Class Expansion Joints**  
**FxF (Flanged Ends) or WxW (Weld Ends)**  
**For up to 16" of movement**

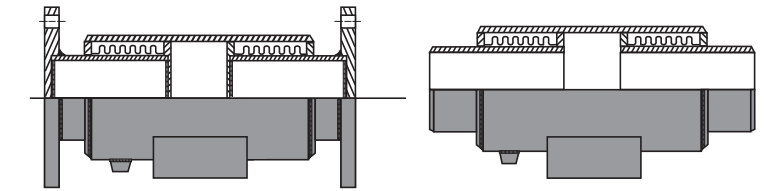

**300# Dual Class Expansion Joints**  
**FxF (Flanged Ends) or WxW (Weld Ends)**  
**For up to 16" of movement**



**Flexpress FPD-FxF150/FPD-WxW150**

**Design Pressure 150 PSIG • Test Pressure 225 PSIG**

I.D. (In.)	Bellows Area (Sq. In.)	Length (In.)		Movement Capability (In.)		Weight (Lbs.)	
		FP/150-FxF	FP/150-WxW	Compression	Extension	FP/150-FxF	FP/150-WxW
2.00	12	43.25	39.50	8.00	1.50	70.00	60.00
		61.25	57.25	12.00	2.25	95.00	85.00
		75.25	71.50	16.00	3.00	112.00	102.00
2.50	12	43.25	39.50	8.00	1.50	79.00	65.00
		61.25	57.25	12.00	2.25	106.00	92.00
		75.25	71.50	16.00	3.00	126.00	112.00
3.00	16	41.25	37.50	8.00	1.50	98.00	82.00
		54.25	50.25	12.00	2.25	120.00	104.00
		71.25	67.50	16.00	3.00	154.00	138.00
4.00	30	42.50	38.75	8.00	1.50	153.00	127.00
		56.00	52.00	12.00	2.25	188.00	162.00
		73.75	70.00	16.00	3.00	242.00	216.00
5.00	42	40.25	36.00	8.00	1.50	200.00	170.00
		52.50	48.00	12.00	2.25	242.00	212.00
		64.75	60.50	16.00	3.00	286.00	296.00
6.00	53	40.25	36.25	8.00	1.50	222.00	184.00
		52.50	48.25	12.00	2.25	268.00	230.00
		64.75	60.75	16.00	3.00	316.00	278.00
8.00	83	42.50	38.25	8.00	1.50	320.00	260.00
		55.75	51.25	12.00	2.25	414.00	354.00
		69.00	64.75	16.00	3.00	490.00	430.00
10.00	135	45.25	40.50	8.00	2.00	450.00	364.00
		59.50	54.75	12.00	3.00	554.00	468.00
		78.00	73.25	16.00	4.00	706.00	620.00
12.00	182	47.25	42.25	8.00	2.00	583.00	455.00
		62.50	57.25	12.00	3.00	717.00	589.00
		81.75	76.75	16.00	4.00	907.00	779.00
14.00	212	47.50	42.25	8.00	2.00	709.00	529.00
		62.75	57.25	12.00	3.00	857.00	677.00
		82.00	76.75	16.00	4.00	1069.00	889.00
16.00	276	48.00	42.25	8.00	2.00	774.00	574.00
		63.25	57.25	12.00	3.00	940.00	740.00
		82.50	76.75	16.00	4.00	1176.00	976.00
18.00	338	48.25	42.25	8.00	2.00	893.00	633.00
		63.50	57.25	12.00	3.00	1077.00	817.00
		82.75	76.75	16.00	4.00	1341.00	1081.00
20.00	404	49.00	42.25	8.00	2.00	1054.00	724.00
		64.25	57.25	12.00	3.00	1254.00	924.00
		83.50	76.75	16.00	4.00	1544.00	1214.00
22.00	481	49.25	42.25	8.00	2.00	1128.00	758.00
		64.50	57.25	12.00	3.00	1348.00	978.00
		84.75	76.75	16.00	4.00	1662.00	1292.00
24.00	562	49.50	42.25	8.00	2.00	1292.00	852.00
		64.75	57.25	12.00	3.00	1528.00	1088.00
		84.00	76.75	16.00	4.00	1870.00	1430.00

**Flexpress FPD-FxF300/FPD-WxW300**

**Design Pressure 300 PSIG • Test Pressure 450 PSIG**

I.D. (In.)	Bellows Area (Sq. In.)	Length (In.)		Movement Capability (In.)		Weight (Lbs.)	
		FP/300-FxF	FP/300-WxW	Compression	Extension	FP/300-FxF	FP/300-WxW
2.00	12	43.25	39.50	8.00	1.50	76.00	62.00
		61.25	57.25	12.00	2.25	103.00	89.00
		75.25	71.50	16.00	3.00	123.00	109.00
2.50	12	43.25	39.50	8.00	1.50	87.00	67.00
		61.25	57.25	12.00	2.25	117.00	97.00
		75.25	71.50	16.00	3.00	138.00	118.00
3.00	16	41.25	37.50	8.00	1.50	110.00	82.00
		54.25	50.25	12.00	2.25	134.00	106.00
		71.25	67.50	16.00	3.00	172.00	146.00
4.00	30	42.50	38.75	8.00	1.50	177.00	133.00
		56.00	52.00	12.00	2.25	215.00	171.00
		73.75	70.00	16.00	3.00	275.00	231.00
5.00	42	40.25	36.00	8.00	1.50	230.00	174.00
		52.50	48.00	12.00	2.25	276.00	220.00
		64.75	60.50	16.00	3.00	322.00	266.00
6.00	53	40.25	36.25	8.00	1.50	270.00	192.00
		52.50	48.25	12.00	2.25	318.00	240.00
		64.75	60.75	16.00	3.00	368.00	290.00
8.00	83	42.50	38.25	8.00	1.50	416.00	294.00
		55.75	51.25	12.00	2.25	492.00	376.00
		69.00	64.75	16.00	3.00	574.00	458.00
10.00	135	45.25	40.50	8.00	2.00	540.00	378.00
		59.50	54.75	12.00	3.00	651.00	489.00
		78.00	73.25	16.00	4.00	816.00	654.00
12.00	182	47.25	42.25	8.00	2.00	741.00	511.00
		62.50	57.25	12.00	3.00	881.00	651.00
		81.75	76.75	16.00	4.00	1085.00	855.00
14.00	212	47.50	42.25	8.00	2.00	1003.00	673.00
		62.75	57.25	12.00	3.00	1193.00	863.00
		82.00	76.75	16.00	4.00	1471.00	1141.00
16.00	276	48.00	42.25	8.00	2.00	944.00	750.00
		63.25	57.25	12.00	3.00	1158.00	964.00
		82.50	76.75	16.00	4.00	1468.00	1274.00
18.00	338	48.25	42.25	8.00	2.00	1332.00	832.00
		63.50	57.25	12.00	3.00	1568.00	1068.00
		82.75	76.75	16.00	4.00	1912.00	1412.00
20.00	404	49.00	42.25	8.00	2.00	1646.00	1016.00
		64.25	57.25	12.00	3.00	1904.00	1274.00
		83.50	76.75	16.00	4.00	2282.00	1652.00
22.00	481	49.25	42.25	8.00	2.00	1738.00	998.00
		64.50	57.25	12.00	3.00	2018.00	1278.00
		84.75	76.75	16.00	4.00	2430.00	1690.00
24.00	562	49.50	42.25	8.00	2.00	2028.00	1078.00
		64.75	57.25	12.00	3.00	2332.00	1382.00
		84.00	76.75	16.00	4.00	2776.00	1826.00



CSA standard B-51 certified. Inspected and tested by the Technical Standards and Safety Authority of Canada.



CSA standard B-51 certified. Inspected and tested by the Technical Standards and Safety Authority of Canada.



**Large Inventory for Immediate Shipment!**

up to 3.25" axial compression    up to .875" axial extension



# Bellowsflex™

BELLOWSFLEX metal bellows type expansion joints are designed for a wide range of service conditions. The standard bellows element is manufactured with 321 stainless steel. Other stainless steel or heat and corrosion resistant alloys are available for bellows and end fittings. Standard pressure ratings up to 300 PSI. Maximum system test pressure 1.5 times maximum working pressure. Available with flanged or beveled weld end fittings. Bellowsflex can also be supplied with accessories such as tie rods, limit rods, flow liners, and protective covers/shrouds.

**Standard Sizes**  
**2" to 24" I.D.**

Custom sizes available up to 60"



CSA standard B-51 certified. Inspected and tested by the Technical Standards and Safety Authority of Canada.

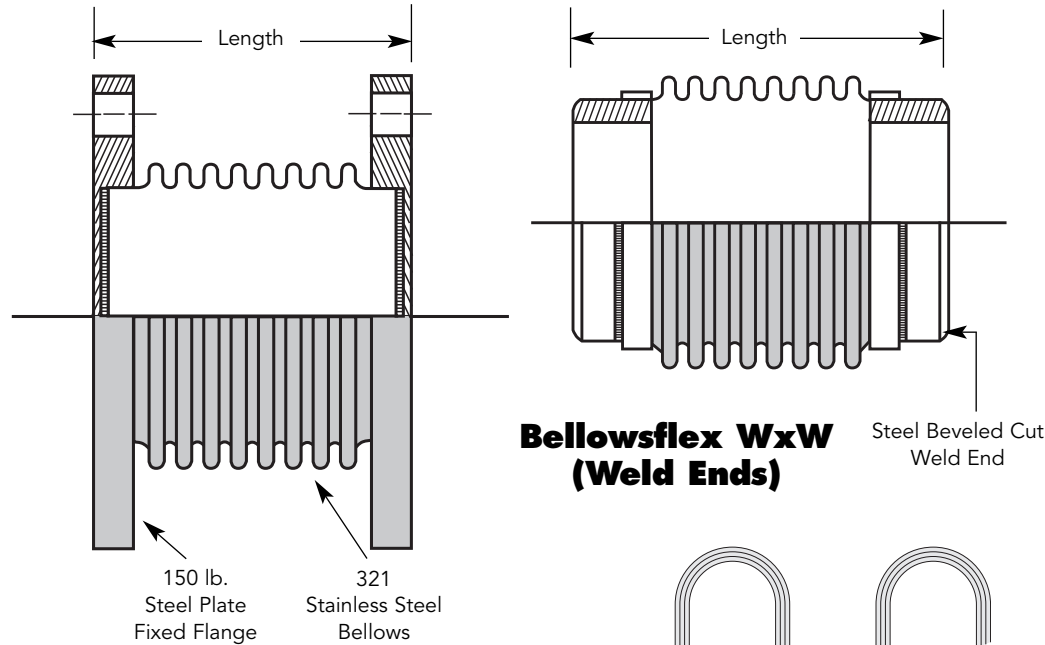

**Bellowsflex FxF (Flanged Ends)**

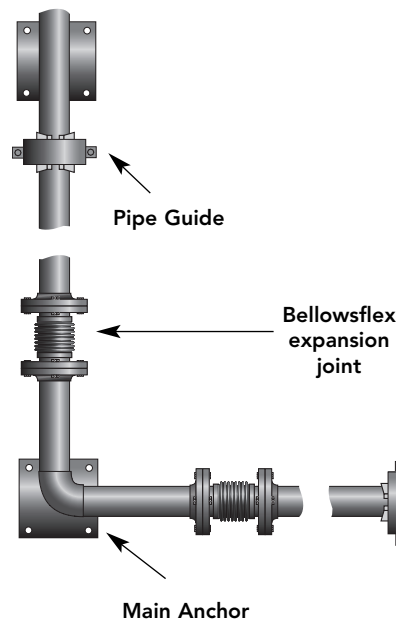

**Optional Multi-Ply Bellows**

Multi-ply bellows provides flexibility and endurance. The reduced thickness of the individual bellows plies results in lower bending stresses due to axial motion increasing the life of the bellows.

**NOTE:** Proper guiding and anchoring is essential to an installation of Bellowsflex expansion joints to prevent buckling or squirming of the pipeline.

For proper guide spacing, see PIPE GUIDE SPACING chart on page 29.

**Typical Bellowsflex Installation**

**Bellowsflex**

Test Pressure 75 PSIG    Design Pressure 50 PSIG    Max Temperature 750°F

I.D. (In.)	Bellows Area (Sq. In.)	Overall Length (In.)						Movement Capability (In.)		Weight (Lbs.)	
		Axial Deflection FxF			Axial Deflection WxW			Compression	Extension	FxF	WxW
2.00	5.90	1.50	2.00	2.50	1.50	2.00	2.50	Note: 80/20 Rule: 80% motion compression/ 20% extension.  Example: Expansion joints rated for 2" total axial travel = 1.60 axial compression .40 axial extension	9.00	2.00	
2.50	8.30	6.00	7.00	8.00	8.00	9.00	10.00		13.00	3.00	
3.00	12.20	6.00	7.00	8.00	8.00	9.00	10.00		14.00	4.00	
4.00	20.10	6.00	7.00	8.00	8.00	9.00	10.00		18.00	6.00	
5.00	30.70	6.00	7.00	8.00	8.00	9.00	10.00		22.00	7.00	
6.00	43.40	6.00	7.00	8.00	8.00	9.00	10.00		27.00	9.00	
<b>Axial Deflection</b>		<b>2.00</b>	<b>2.50</b>	<b>3.00</b>	<b>2.00</b>	<b>2.50</b>	<b>3.00</b>		43.00	15.00	
8.00	72.80	7.00	9.00	9.50	9.00	11.00	11.50		62.00	20.00	
10.00	111.00	7.00	9.00	9.50	9.00	11.00	11.50		91.00	25.00	
12.00	154.00	7.00	9.00	9.50	9.00	11.00	11.50		110.00	29.00	
<b>Axial Deflection</b>		<b>2.00</b>	<b>3.00</b>	<b>3.50</b>	<b>2.00</b>	<b>3.00</b>	<b>3.50</b>		154.00	35.00	
14.00	183.00	7.00	9.00	9.50	10.00	12.00	12.50		172.00	40.00	
16.00	237.00	7.00	9.00	9.50	10.00	12.00	12.50		174.00	42.00	
18.00	299.00	7.00	9.00	9.50	10.00	12.00	12.50	198.00	47.00		
<b>Axial Deflection</b>		<b>2.00</b>	<b>3.00</b>	<b>4.00</b>	<b>2.00</b>	<b>3.00</b>	<b>4.00</b>	247.00	54.00		
20.00	363.00	7.50	10.00	12.50	12.00	14.50	17.00				
22.00	434.00	7.50	10.00	12.50	12.00	14.50	17.00				
24.00	511.00	7.50	10.00	12.50	12.00	14.50	17.00				

Test Pressure 225 PSIG    Design Pressure 150 PSIG    Max Temperature 750°F

I.D. (In.)	Bellows Area (Sq. In.)	Overall Length (In.)						Movement Capability (In.)		Weight (Lbs.)	
		Axial Deflection FxF			Axial Deflection WxW			Compression	Extension	FxF	WxW
2.00	5.90	1.50	2.00	2.50	1.50	2.00	2.50	Note: 80/20 Rule: 80% motion compression/ 20% extension.  Example: Expansion joints rated for 3.50" total axial travel = 2.80 axial compression .70 axial extension	9.00	2.00	
2.50	8.30	6.00	7.00	8.00	8.00	9.00	10.00		13.00	3.00	
3.00	12.20	6.00	7.00	8.00	8.00	9.00	10.00		14.00	4.00	
4.00	20.10	6.00	7.00	8.00	8.00	9.00	10.00		18.00	6.00	
5.00	30.70	6.00	7.00	8.00	8.00	9.00	10.00		22.00	7.00	
6.00	43.40	6.00	7.00	8.00	8.00	9.00	10.00		27.00	9.00	
<b>Axial Deflection</b>		<b>2.00</b>	<b>2.50</b>	<b>3.00</b>	<b>2.00</b>	<b>2.50</b>	<b>3.00</b>		43.00	15.00	
8.00	72.80	8.00	9.00	10.00	11.00	12.00	13.00		62.00	20.00	
10.00	111.00	8.00	9.00	10.00	11.00	12.00	13.00		91.00	25.00	
12.00	154.00	8.00	9.00	10.00	11.00	12.00	13.00		110.00	29.00	
<b>Axial Deflection</b>		<b>2.00</b>	<b>3.00</b>	<b>3.50</b>	<b>2.00</b>	<b>3.00</b>	<b>3.50</b>		154.00	35.00	
16.00	237.00	7.50	10.00	11.00	12.00	14.50	15.50		172.00	40.00	
18.00	299.00	7.50	10.00	11.00	12.00	14.50	15.50		174.00	42.00	
20.00	363.00	7.50	10.00	11.00	12.00	14.50	15.50	198.00	47.00		
22.00	434.00	7.50	10.00	11.00	12.00	14.50	15.50	247.00	54.00		
24.00	511.00	7.50	10.00	11.00	12.00	14.50	15.50				

Test Pressure 450 PSIG    Design Pressure 300 PSIG    Max Temperature 750°F

I.D. (In.)	Bellows Area (Sq. In.)	Overall Length (In.)						Movement Capability (In.)		Weight (Lbs.)	
		Axial Deflection FxF			Axial Deflection WxW			Compression	Extension	FxF	WxW
2.00	5.90	1.00	1.50	2.00	1.00	1.50	2.00	Note: 80/20 Rule: 80% motion compression/ 20% extension.  Example: Expansion joints rated for 3" total axial travel = 2.40 axial compression .60 axial extension	20.00	2.00	
2.50	8.30	6.00	7.00	8.00	8.00	9.00	10.00		25.00	3.00	
3.00	12.20	6.00	7.00	8.00	8.00	9.00	10.00		33.00	4.00	
4.00	20.10	6.00	7.00	8.00	8.00	9.00	10.00		40.00	6.00	
5.00	30.70	6.00	7.00	8.00	8.00	9.00	10.00		49.00	7.00	
6.00	43.40	6.00	7.00	8.00	8.00	9.00	10.00		66.00	9.00	
<b>Axial Deflection</b>		<b>1.50</b>	<b>2.00</b>	<b>2.50</b>	<b>1.50</b>	<b>2.00</b>	<b>2.50</b>		88.00	15.00	
8.00	72.80	9.00	11.00	13.00	11.00	13.00	15.00		124.00	20.00	
10.00	111.00	9.00	11.00	13.00	11.00	13.00	15.00		183.00	25.00	
<b>Axial Deflection</b>		<b>2.00</b>	<b>2.50</b>	<b>3.00</b>	<b>2.00</b>	<b>2.50</b>	<b>3.00</b>		282.00	29.00	
12.00	154.00	10.00	11.50	13.00	13.00	14.50	16.00		368.00	35.00	
14.00	183.00	10.00	11.50	13.00	13.00	14.50	16.00		449.00	40.00	
16.00	237.00	10.00	11.50	13.00	13.00	14.50	16.00		544.00	42.00	
18.00	299.00	10.00	11.50	13.00	13.00	14.50	16.00	676.00	47.00		
20.00	363.00	10.00	11.50	13.00	13.00	14.50	16.00	854.00	54.00		
22.00	434.00	10.00	11.50	13.00	13.00	14.50	16.00				
24.00	511.00	10.00	11.50	13.00	13.00	14.50	16.00				

NOTE: Optional Tie rods and Limit rods available. See page 9.



**Large Inventory for Immediate Shipment!**

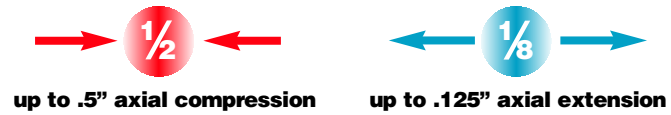

# Pumpflex™

PUMPFLEX bellows pump connector features a 304 series stainless steel bellows construction. Pumpflex has a short face-to-face dimension for compact installations. It is ideal in applications for vibration control and noise reduction as well as strain relief, misalignment and thermal growth in a piping system not to exceed .5" axial compression. Pumpflex features tie rod restraints to prevent elongation, and compression sleeves to prevent over compression. Standard pressure ratings up to 225 PSI. Maximum system test pressure 1.5 times maximum working pressure. Manufactured with a 3:1 safety factor. Available with 150 lb. flat face flanges.

**Standard Sizes  
2" to 12" I.D.**

*Additional alloys, styles, sizes and higher working pressures available. Please consult factory.*

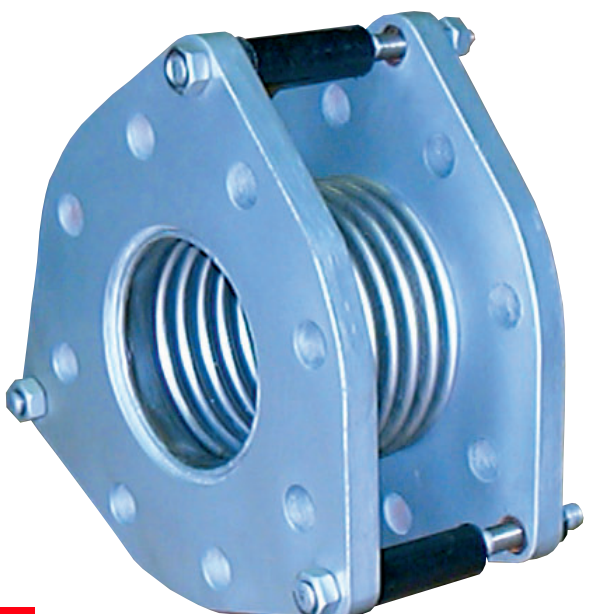
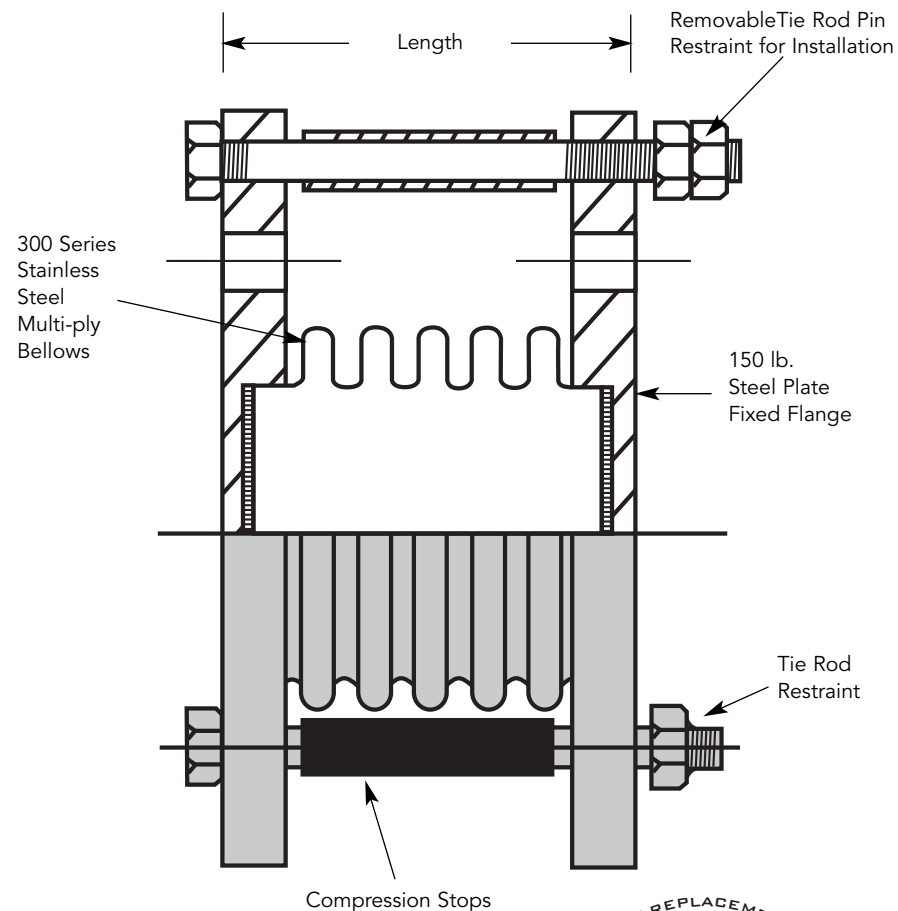

**OPTIONAL VANSTONE FLANGE**

Vanstone flanges provide a cost-effective means of isolating the media from the standard carbon steel flange. The Vanstone option, without the use of tie rods, allows full rotation of the backup flange to allow for bolt hole alignment.

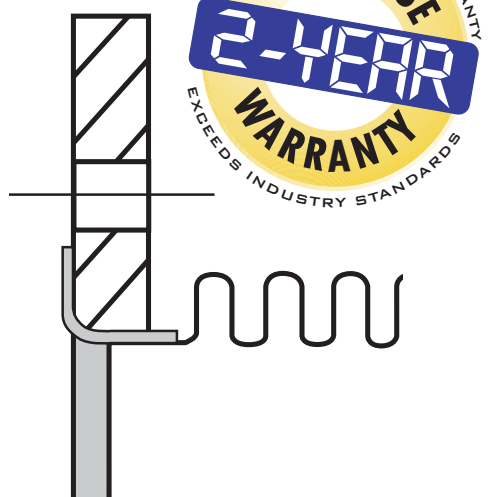

I.D. (In.)	Length (In.)	Pressure (PSI)		Movement Capability (In.)			Weight (Lbs.)
		70°F	360°F	Compression	Extension	Parallel	
2.00	4.375	225	210	.50	.125	.125	11.00
2.50	4.375	225	210	.50	.125	.125	15.00
3.00	4.375	225	210	.50	.125	.125	17.00
4.00	4.625	225	210	.50	.125	.125	27.00
5.00	4.875	225	210	.50	.125	.125	33.00
6.00	5.000	225	210	.50	.125	.125	38.00
8.00	5.875	225	210	.50	.125	.125	66.00
10.00	6.250	225	210	.50	.125	.125	87.00
12.00	6.625	225	210	.50	.125	.125	114.00

**NOTE:** Custom sizes and higher working pressures available. Please consult factory.

**Typical Pumpflex Installation**

Typical piping layout showing Pumpflex installation within a properly anchored system.

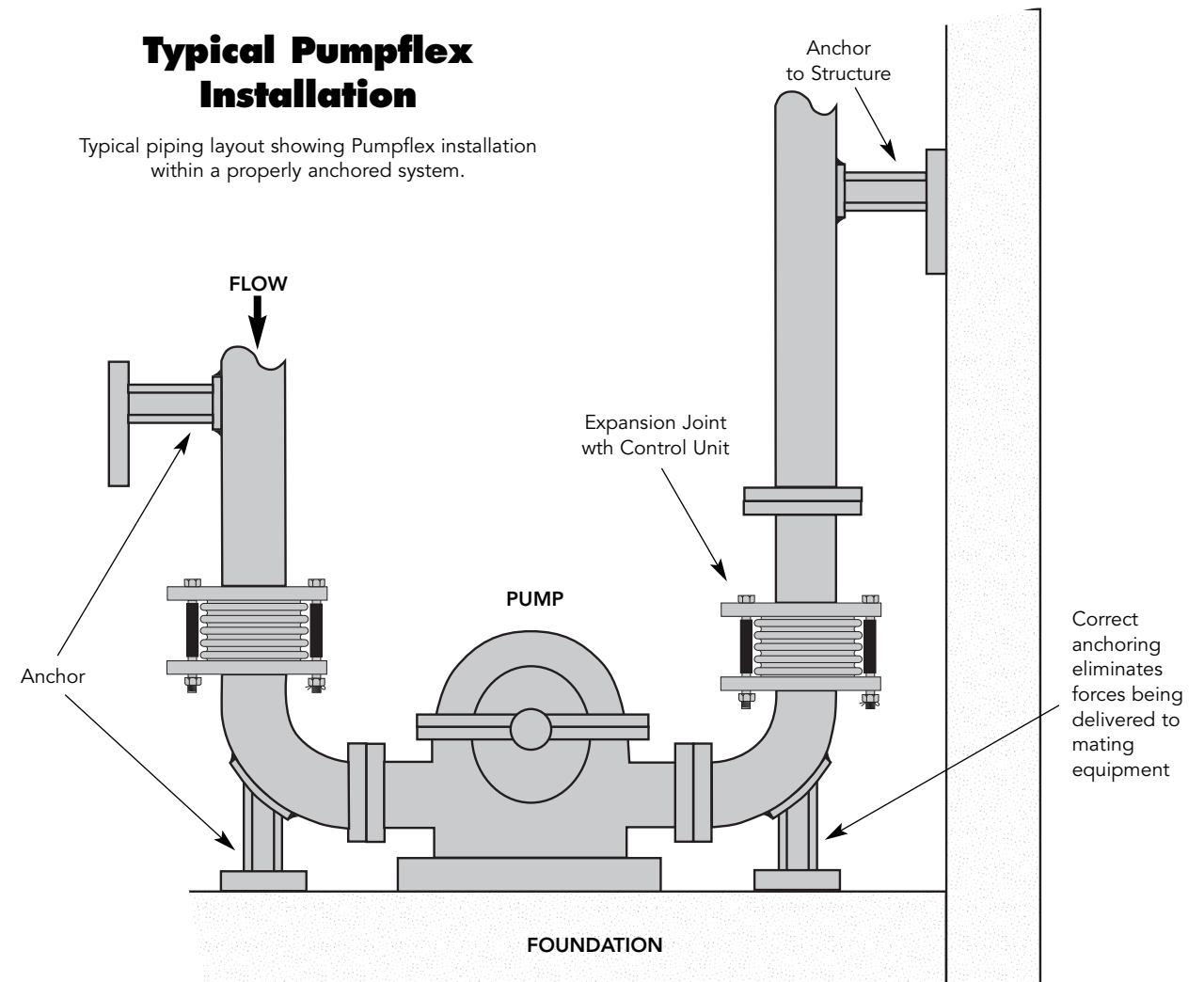



Large Inventory for Immediate Shipment!



# BellowsXhaust™

BELLOWSXHAUST expansion joints are designed to absorb pipe expansion, reduce noise, and dampen vibration. They are ideal for low pressure (up to 50 psi) and high temperature (1200°F) applications. The assembly weights have been reduced to permit use in thin wall flue duct systems.

Most common applications are exhaust connections on diesel, gasoline or gas turbine engine installations and ducting conveying corrosive gases. To simplify selection, standard designs have been developed with a 321 stainless steel bellows element. BellowsXhaust are available with flanged ends, weld ends, and optional vanstone flanges with axial travel up to 3.5 inches.

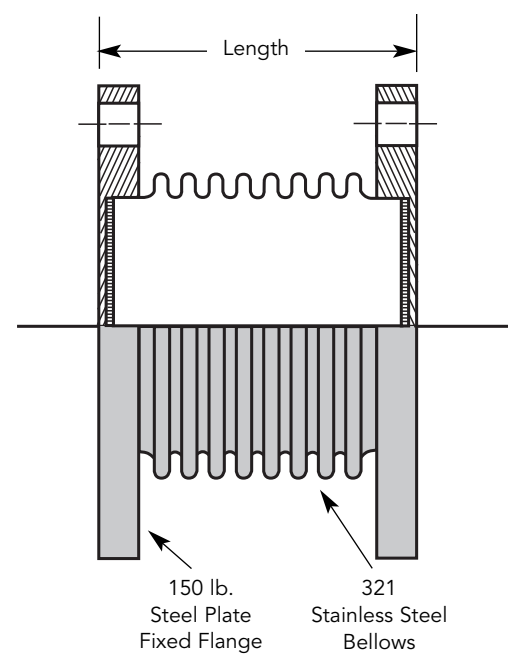

**BellowsXhaust FxF (Flanged Ends)**

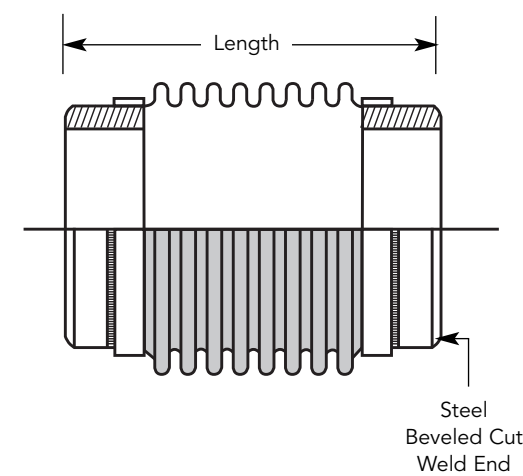

**BellowsXhaust WxW (Weld Ends)**

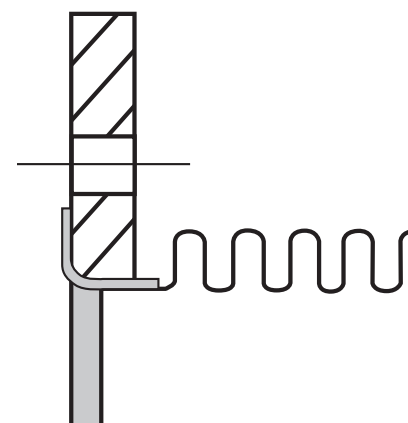

**OPTIONAL VANSTONE FLANGE**  
Vanstone flanges provide a cost-effective means of isolating a corrosive gaseous media from the standard carbon steel flange vs. a bellows exhaust unit with high alloy flanges. The Vanstone design are rotatable for ease of bolt hole alignment.

**Standard Sizes 4" to 48" I.D.**

Other corrosion resistant alloys available. Please consult factory.



BellowsXhaust											
Max Design Pressure 50 PSIG • Test Pressure 75 PSIG • Max Temperature 1200°F											
I.D. (In.)	Bellows Area (Sq. In.)	Overall Length (In.)								Weight (Lbs.)	
		Axial Compression				Axial Extension				FxF	WxW
		1.00	2.00	2.50	3.50	0.50	1.00	1.30	1.50		
4.00	20.10	7.00	10.00	11.00	12.00	7.00	10.00	11.00	12.00	18.00	6.00
5.00	30.70	7.00	10.00	11.00	12.00	7.00	10.00	11.00	12.00	22.00	7.00
6.00	43.40	7.00	10.00	11.00	12.00	7.00	10.00	11.00	12.00	27.00	9.00
8.00	72.80	7.00	10.00	11.00	12.00	7.00	10.00	11.00	12.00	43.00	15.00
10.00	111.00	8.00	11.00	12.00	13.00	8.00	11.00	12.00	13.00	62.00	20.00
12.00	154.00	8.00	11.00	12.00	13.00	8.00	11.00	12.00	13.00	91.00	25.00
Axial Comp./Ext.		2.00	2.50	3.00	3.50	1.00	1.30	1.50	1.80		
14.00	111.00	12.00	13.00	14.00	15.00	12.00	13.00	14.00	15.00	110.00	29.00
16.00	154.00	12.00	13.00	14.00	15.00	12.00	13.00	14.00	15.00	154.00	35.00
18.00	183.00	12.00	13.00	14.00	15.00	12.00	13.00	14.00	15.00	172.00	40.00
20.00	237.00	13.00	14.00	15.00	17.00	13.00	14.00	15.00	17.00	174.00	42.00
22.00	299.00	13.00	14.00	15.00	17.00	13.00	14.00	15.00	17.00	198.00	47.00
24.00	363.00	13.00	14.00	15.00	17.00	13.00	14.00	15.00	17.00	247.00	54.00
26.00	434.00	13.00	14.00	15.00	17.00	13.00	14.00	15.00	17.00	284.00	60.00
28.00	511.00	13.00	14.00	15.00	17.00	13.00	14.00	15.00	17.00	311.00	68.00
Axial Comp./Ext.		2.00	3.00	3.50		1.00	1.50	1.80			
30.00	789.00	14.00	16.00	18.00		14.00	16.00	18.00		361.00	73.00
32.00	895.00	14.00	16.00	18.00		14.00	16.00	18.00		465.00	85.00
34.00	1005.00	14.00	16.00	18.00		14.00	16.00	18.00		484.00	89.00
36.00	1125.00	14.00	16.00	18.00		14.00	16.00	18.00		575.00	100.00
38.00	1245.00	14.00	16.00	18.00		14.00	16.00	18.00		663.00	111.00
40.00	1375.00	14.00	16.00	18.00		14.00	16.00	18.00		689.00	116.00
42.00	1510.00	14.00	16.00	18.00		14.00	16.00	18.00		801.00	129.00
44.00	1655.00	14.00	16.00	18.00		14.00	16.00	18.00		852.00	136.00
46.00	1800.00	14.00	16.00	18.00		14.00	16.00	18.00		889.00	142.00
48.00	1955.00	14.00	16.00	18.00		14.00	16.00	18.00		1012.00	156.00

NOTE: Bellows spring rates are available. Please consult factory.

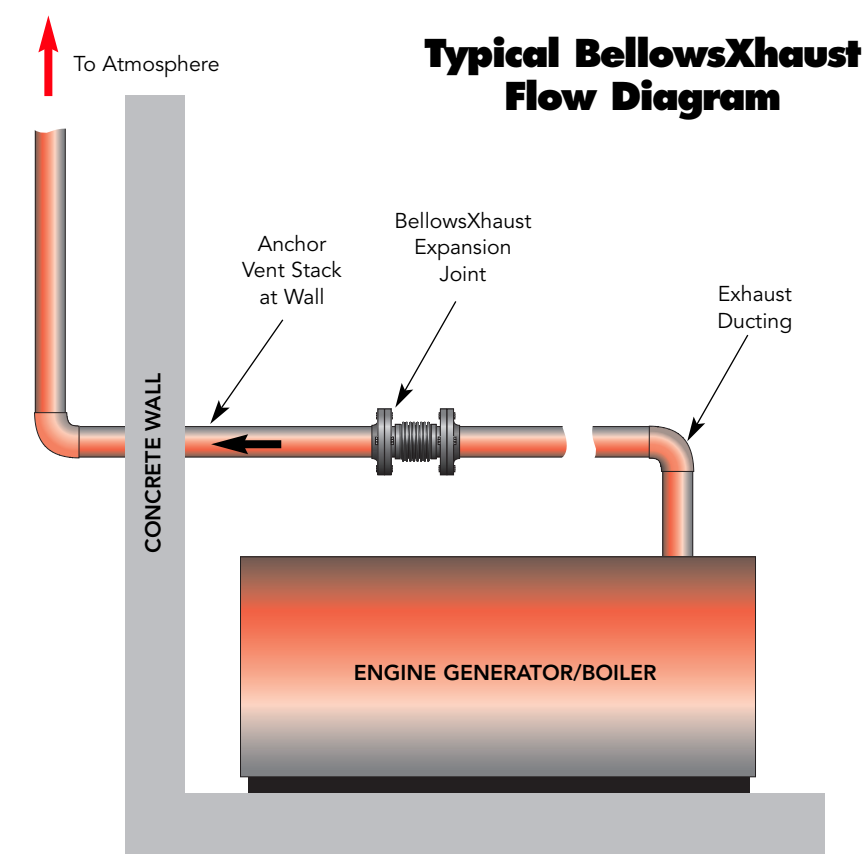





# Guideline™

GUIDELINE pipe alignment guides are designed to maintain the longitudinal position of the pipe's centerline with minimal axial restraints. Proper pipe guiding is vital for safe operation of piping systems incorporating the use of expansion joints or use of mechanical hard pipe loops. The use of traditional pipe supports (rollers, clevis hangers or U-bolts) do not assure the pipe is guided axially. Guideline assures safety of your expansion joint system. Sizing is determined by the pipe size, axial movement and the amount of pipe insulation to be used. Copper tube guides are supplied with dielectric spacers to prevent galvanic corrosion. The two piece inside spider and two piece guiding sleeve of the Guideline provide easy bolt on installation.

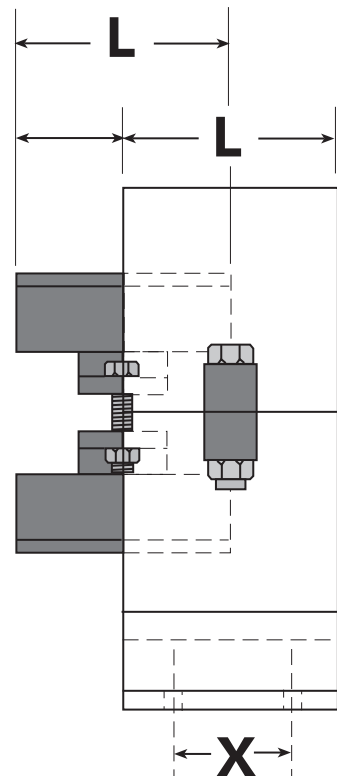
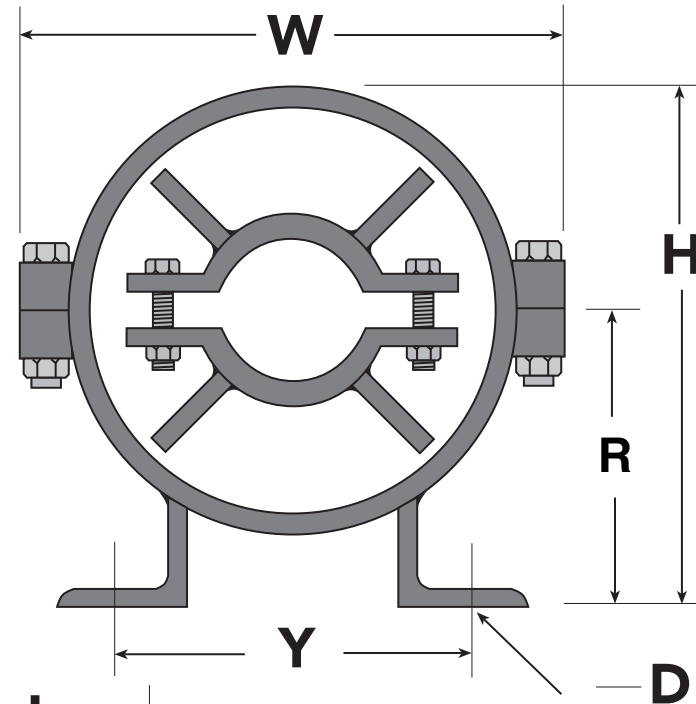

**NOTE:** The recommendations given for pipe anchors and guides represent the minimum requirements for controlling pipelines which contain expansion joints and are intended to protect the expansion joint and pipe system from abuse and failure. However, additional **pipe supports** are often required between the pipe guides in accordance with accepted piping practices.

A **pipe support** is any device which permits free movement of the piping and carries the total weight of in line equipment such as valves, meters, expansion joints, and the weight of the contained fluid. Pipe supports cannot be substituted for pipe alignment guides. Pipe rings, U-bolts, roller supports, and spring hangers are some examples of conventional pipe supports.

## Standard Sizes ½" to 24" I.D.



## Guideline Pipe/Tube Alignment Guides

1.50" MAXIMUM INSULATION										2.00" MAXIMUM INSULATION											
Nom. Pipe Size (In.)	Max. Axial Mvmt (In.)	General								Wt. (Lb.)	Nom. Pipe Size (In.)	Max. Axial Mvmt (In.)	General								Wt. (Lb.)
		W	H	R	Y	X	D	L	W				H	R	Y	X	D	L			
.75	4.00	7.13	6.75	4.00	4.38	1.75	.63	3.00	8.00	.75	4.00	8.13	7.63	4.38	5.13	1.75	.63	3.00	9.00		
1.00	4.00	7.13	6.75	4.00	4.38	1.75	.63	3.00	8.00	1.00	4.00	8.13	7.63	4.38	5.13	1.75	.63	3.00	9.00		
1.25	4.00	7.13	6.75	4.00	4.38	1.75	.63	3.00	8.00	1.25	4.00	8.13	7.63	4.38	5.13	1.75	.63	3.00	9.00		
1.50	4.00	7.13	6.75	4.00	4.38	1.75	.63	3.00	8.00	1.50	4.00	8.13	7.63	4.38	5.13	1.75	.63	3.00	9.00		
2.00	4.00	8.13	7.63	4.38	5.13	1.75	.63	3.00	9.00	2.00	4.00	10.13	9.25	5.25	6.13	1.75	.63	3.00	11.00		
2.50	4.00	8.13	7.63	4.38	5.13	1.75	.63	3.00	9.00	2.50	4.00	10.13	9.25	5.25	6.13	1.75	.63	3.00	11.00		
3.00	4.00	10.13	9.25	5.25	6.13	1.75	.63	3.00	11.00	3.00	4.00	10.13	9.25	5.25	6.13	1.75	.63	3.00	11.00		
4.00	4.00	10.13	9.25	5.25	6.13	1.75	.63	3.00	11.00	4.00	4.00	12.13	11.63	6.25	7.00	2.75	.63	4.00	17.00		
5.00	4.00	12.13	11.63	6.25	7.00	2.75	.63	4.00	17.00	5.00	4.00	12.13	11.63	6.25	7.00	2.75	.63	4.00	17.00		
6.00	4.00	12.13	11.63	6.25	7.00	2.75	.63	4.00	17.00	6.00	4.00	14.13	13.38	7.00	8.25	2.75	.63	4.00	20.00		
8.00	4.00	14.13	13.38	7.00	8.25	2.75	.63	4.00	20.00	8.00	6.00	16.13	15.13	7.88	9.88	4.00	.75	6.00	40.00		
10.00	6.00	18.13	17.00	8.88	10.88	4.00	.75	6.00	48.00	10.00	6.00	18.13	17.00	8.88	10.88	4.00	.75	6.00	48.00		
12.00	6.00	20.13	18.75	9.75	11.88	4.00	.75	6.00	54.00	12.00	6.00	20.13	18.75	9.75	11.88	4.00	.75	6.00	54.00		
14.00	6.00	22.13	21.00	10.88	11.75	4.00	.75	6.00	61.00	14.00	6.00	22.13	21.00	10.88	11.75	4.00	.75	6.00	61.00		
16.00	8.00	24.13	23.13	12.13	14.50	6.00	.88	8.00	89.00	16.00	8.00	24.13	23.13	12.13	14.50	6.00	.88	8.00	89.00		
18.00	8.00	26.13	25.00	13.00	15.50	6.00	.88	8.00	102.00	18.00	8.00	26.13	25.00	13.00	15.50	6.00	.88	8.00	102.00		
20.00	8.00	28.13	27.75	14.75	17.13	6.00	1.13	8.00	110.00	20.00	8.00	28.13	27.75	14.75	17.13	6.00	1.13	8.00	110.00		
24.00	8.00	32.13	31.50	16.50	19.25	6.00	1.13	8.00	150.00	24.00	8.00	32.13	31.50	16.50	19.25	6.00	1.13	8.00	150.00		

**NOTE:** Pipe guides for greater insulation thickness and pipe movements available. Please consult factory.

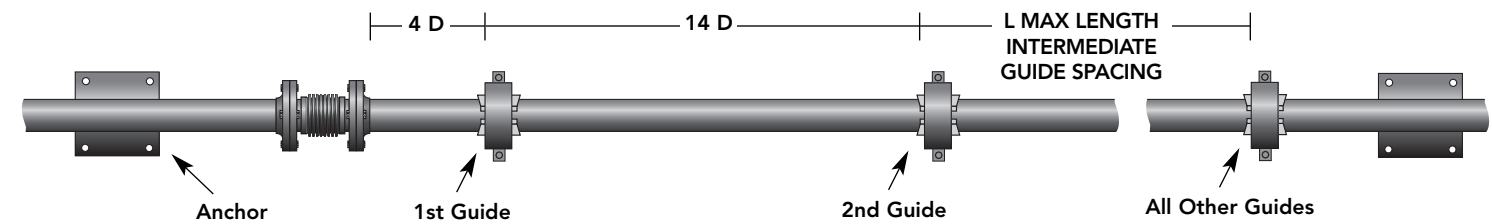

**NOTE:** First pipe guide must be located within a distance no greater than four pipe diameters from the end of the bellows and the second guide must be located within a distance no greater than fourteen pipe diameters from the first guide.

## Intermediate Pipe Guided Spacing

Nom. Pipe Size (In.)	Maximum Distance from Expansion Joint to 1st Guide or Anchor	Approx. Distance Between 1st and 2nd Guide	Approximate Distance Between Additional Pipe Guides (Ft.)							
			@ 50 PSI	@ 100 PSI	@ 150 PSI	@ 200 PSI	@ 250 PSI	@ 300 PSI	@ 350 PSI	@ 400 PSI
.75	3.00"	10.00"	11.00	7.50	6.00	5.00	5.50	5.00	5.00	5.00
1.00	4.00"	1'-2.00"	15.00	11.00	8.50	7.50	6.50	6.00	5.50	5.0
1.25	5.00"	1'-5.00"	17.00	13.00	11.00	9.00	8.00	7.25	7.00	6.50
1.50	6.00"	1'-9.00"	22.00	16.00	13.00	11.00	10.00	9.00	8.50	8.00
2.00	8.00"	2'-4.00"	25.00	18.00	14.00	13.00	12.00	11.00	9.50	9.00
2.50	10.00"	2'-11.00"	32.00	23.00	17.00	16.00	14.00	13.00	12.00	11.00
3.00	1'-0"	3'-6.00"	38.00	27.00	22.00	19.00	17.00	16.00	15.00	14.00
4.00	1'-4.00"	4'-8.00"	52.00	37.00	31.00	27.00	24.00	22.00	20.00	18.00
5.00	1'-8.00"	5'-10.00"	62.00	45.00	37.00	32.00	28.00	27.00	24.00	23.00
6.00	2'-0"	7'-0"	67.00	47.00	39.00	34.00	32.00	28.00	26.00	24.00
8.00	2'-8.00"	9'-4.00"	86.00	62.00	51.00	44.00	40.00	36.00	34.00	32.00
10.00	3'-4.00"	11'-8.00"	109.00	76.00	63.00	55.00	48.00	45.00	42.00	38.00
12.00	4'-0"	14'-0"	117.00	84.00	68.00	60.00	54.00	47.00	45.00	42.00
14.00	4'-8.00"	16'-4.00"	120.00	88.00	72.00	62.00	55.00	51.00	46.00	44.00
16.00	5'-4.00"	18'-8.00"	133.00	95.00	78.00	67.00	62.00	55.00	52.00	48.00
18.00	6'-0"	21'-0"	151.00	105.00	87.00	75.00	67.00	62.00	58.00	54.00
20.00	6'-8.00"	23'-4.00"	160.00	107.00	93.00	81.00	72.00	65.00	62.00	57.00
24.00	8'-0"	24'-0"	181.00	130.00	105.00	92.00	85.00	75.00	70.00	65.00